

Assembly Instruction

Note: Any length Epicenter overhead storage may straddle the top of the Epicenter frame when properly supported by undersurface storage. The stanchions vary in length depending on the configuration. All worksurfaces should be located in the user position before installing the overhead.

1

Using a phillips head screwdriver remove the screws from the preattached brackets. Slide the stanchions over the brackets. Using a phillips head screwdriver, attach two (2) screws per stanchion into the thread holes of the bracket (Figure A).

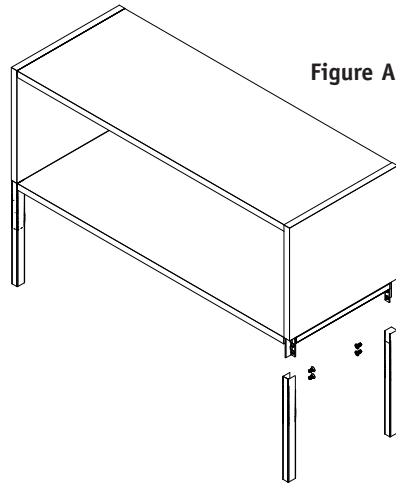

Figure A

2

In the desired location, position the overhead. **Note:** Place masking tape where the stanchions intersect with the worksurface. Using a tape measure and pencil, mark the center of a stanchion. Reference (Figure B) to find your size unit, mark the other hole using a tape measure and pencil.

Caution: Insure all worksurfaces, upper and lower, are positioned in the user location (Figure E).

Figure B

Model	Length
30"	29 1/8"
36"	35 1/8"
42"	41 18/16"
48"	47 1/16"
54"	53 1/16"
60"	59 1/16"

3

Using a drill with a 3/8" bit bore a hole 5/8" deep in each worksurface that was marked (Figure C).

Figure C

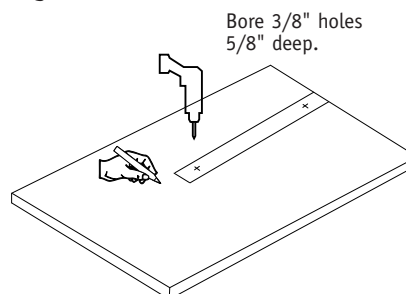

Epicenter Overhead

Recommended Tools

- Drill with 3/8" Bit
- Phillips Head Screwdriver
- Tape Measure
- Masking Tape
- Pencil
- Hammer

Package Contents

- | | Qty. |
|--------------------------------------|-------|
| • Overhead | 1 |
| • Stanchion Kit with four stanchions | (4) 1 |
| • Split Ring | 4 |

NATIONAL

Furniture with Personality®

Telephone 800.482.1717
Fax 812.482.8800
www.NationalOfficeFurniture.com

Part #2351867
Rev,-

Printed in U.S.A
© 2011 Kimball International, Inc.

Proper product installation, in accordance with these instructions, is the responsibility of the installing agent. If you have any questions concerning these instructions, please call National Customer Service 800.482.1717.

Assembly Instruction

Epicenter Overhead

4

Using a hammer, drive a split ring into each of the bored holes. Align the holes in the bottom of the overhead stanchions with each split ring. Set the stanchions flush upon each worksurface (Figure D).

Figure D

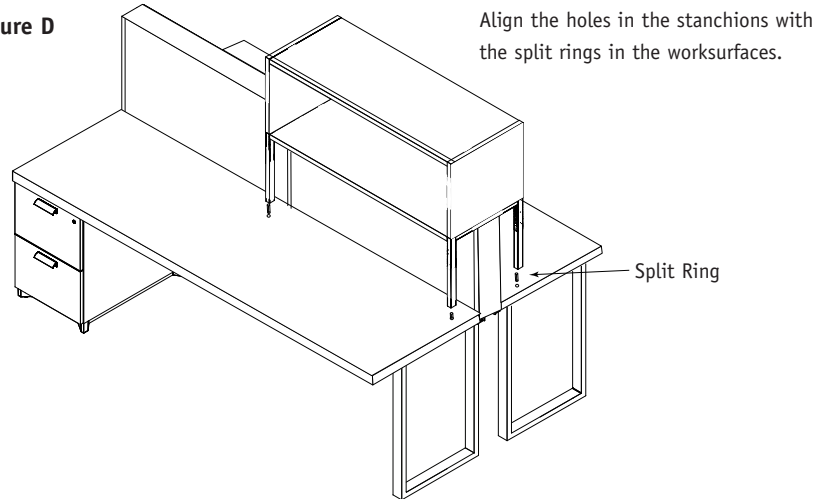

Note: Depending on the configuration the leg lengths can vary from side to side and from end to end (Figure E).

Figure E

