

Lateral File
Drawer Removal
Anti-Tip Mechanism

- Recommended Tools
- Phillips Screwdriver

1

Lateral file units are equipped with an anti-tip mechanism. This consists of a cable that is threaded to inserts on the rear of the top and bottom drawers and threaded through eyelets on the middle two drawers and back panel. This allows only one drawer to be opened at a time.

2

To Remove the Drawers:

Unlock the unit and extend the TOP DRAWER forward. Unscrew the cable from the rear of the drawer (Figure A).

Figure A

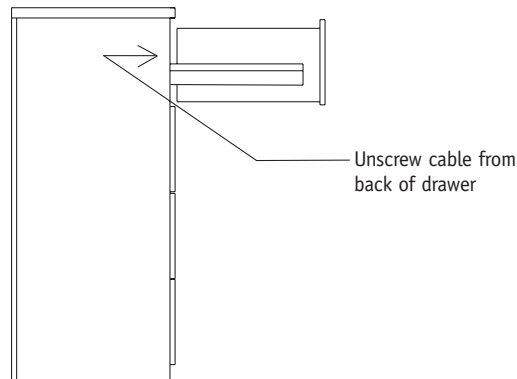

3

Press the quick-disconnect tabs on each side of the drawer and pull forward and upward to remove the drawer from the slide assembly (Figure B).

NOTE: Shipping screws must be removed from drawer suspensions on each side before drawer can be removed.

Figure B

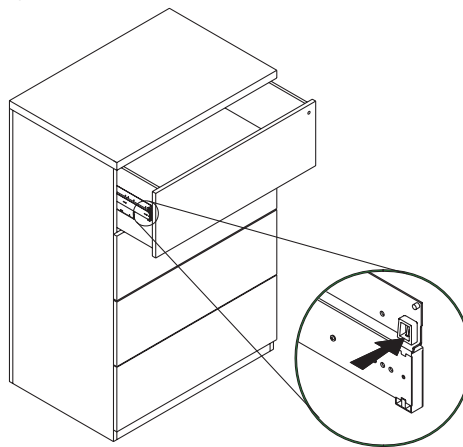

4

Cable must be removed from eyelets on rear of middle two drawers if those drawers are to be removed. Cable is attached to an insert on rear of bottom drawer. Unscrew cable from insert to remove the bottom drawer (Figure C).

Figure C

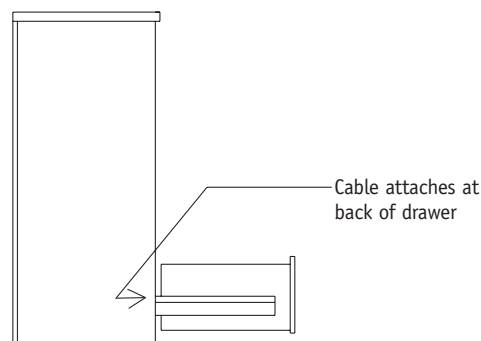

Proper product installation, in accordance with these instructions, is the responsibility of the installing agent. If you have any questions concerning these instructions, please call National Customer Care Teams.

NATIONAL

Furniture with Personality®

Telephone 800.482.1717
Fax 812.482.8800
www.nationalonline.com

Part #2034581

Lateral File
Drawer Removal
Anti-Tip Mechanism

5

To Re-install Drawers:

Start with the bottom drawer. Re-insert drawer into slides. Thread cable into threaded inserts on back of drawer. Insert cable through eyelet in back panel of lateral file. Repeat process with middle two drawers, alternately threading cable through eyelets on back of drawers and eyelets in back panel. For top drawer, insert cable into threaded insert on back of drawer (Figure D).

Figure D

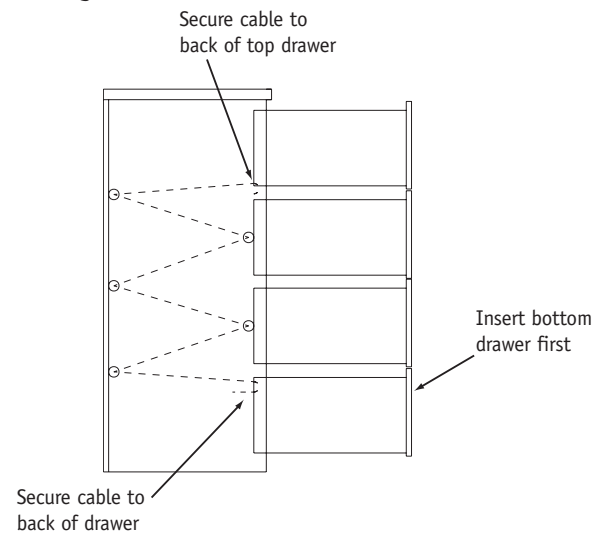

6

When all drawers are replaced, open bottom drawer and loosen cable and pull to remove all slack. Secure cable to back of drawer (Figure E).

Figure E

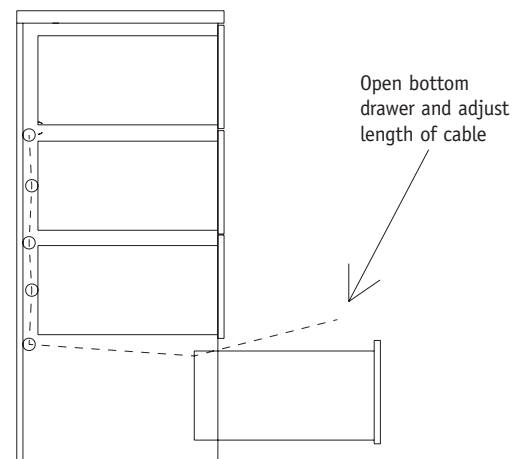

7

Close the bottom drawer and open any one of the others. If this drawer does not fully open, adjust the cable so that only one drawer can be fully open at one time (Figure F).

Figure F

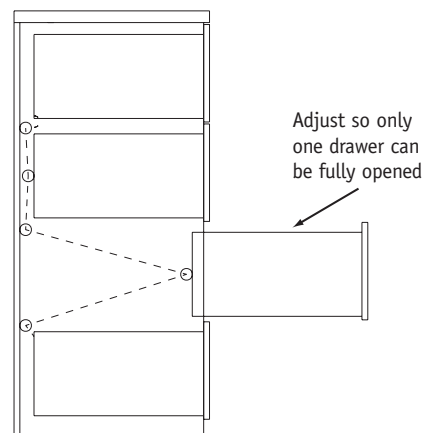

8

To remove the drawers in a two (2) drawer unit, pull out drawer and unscrew cable from back of drawer then follow Step 3.