

**1**

Insert Microphone in the pre-mounted anti-shock plate, attach to patch cable (Figure A). **Note:** Reference Microphone specification sheet for Technical specifications.

The Deluxe Lectern is equipped with a sliding side shelf. The shelf will slide out from either side. Insert your fingers in one side of the shelf opening and push (Figure A).

**Note:** Maximum distributed load of shelf is 30lbs, do not over load.

**2**

The Deluxe Lectern is equipped with front casters to aid in positioning. Ensure the step is in the closed position and the Hinged Front panel is latched securely. Lift up on the user side of unit and push in desired direction.

**Note:** If the Lectern needs to be moved along uneven flooring or significant distances it is recommended two (2) or more individuals be used to move.

**3**

The Deluxe Lectern is equipped with a pull out step. Place hand in cut out and pull until the step reaches its stop.

**Note:** The Step has a maximum load rate of 250lbs.

**Figure A**

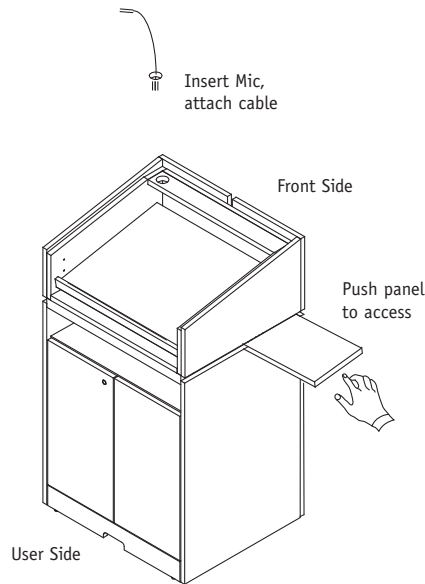

**Figure B**

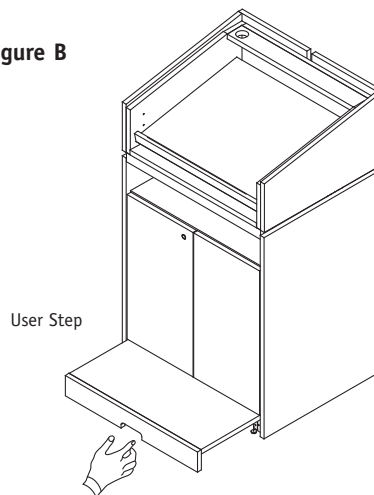

## Conference and Training Solutions Deluxe Lectern

### Recommended Tools

- None

### Package Contents

### Qty.

- | Package Contents | Qty. |
|------------------|------|
| • Microphone     | 1    |

**NATIONAL** | Furniture with Personality™

Telephone 800.482.1717  
Fax 812.482.8800  
www.nationalofficefurniture.com

Part #2142870  
Rev,-

Printed in U.S.A  
© 2008 Kimball International, Inc.

## Assembly Instructions

### Deluxe Lectern

**4** The Deluxe Lectern is equipped with a hinged Front access panel. To open, unlock the user side doors. Reach through the unit to release the Roster Catch (Figure C). When finished accessing the front of the unit, ensure the Roster Catch latches when closing the panel.

**5** The Deluxe Lectern is equipped with a LED light (Figure C). Ensure it is plugged into the attached power strip and is plugged into an outlet.

Figure C

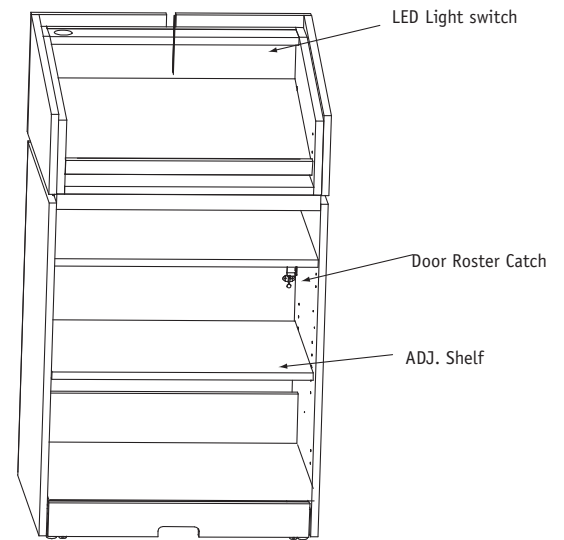

**Note:** Doors have been removed for veiwing.

**6** The Deluxe Lectern is equipped with an adjustable writing shelf. During shipping the Shelf is positioned in the lowest setting and retained by the shelf clips. Remove the clips and position them in the desired location. In the top position the shelf will be level to accommodate a laptop, etc. The other positions are inclined (Figure D).

Figure D

