

1

Ganging Units

A Vertical Storage Unit may be "ganged" to a combination of a credenza or a credenza and a Media Wall.

Note: All floor units and base units supporting above surface storage units MUST be leveled as described in the Leveling Assembly Instruction.

Fasten units together using the #8 x 1 1/4" PH screws provided. Use a minimum of four (4) screws at the widest spacing possible to achieve the strongest and most stable assembly (Figure A).

Figure A

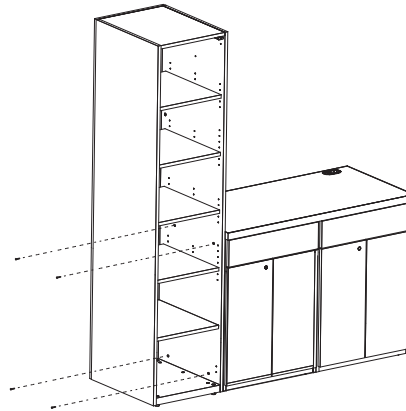

Figure B

Scrap wood support block

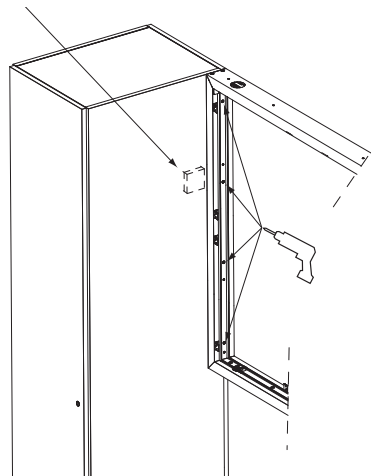
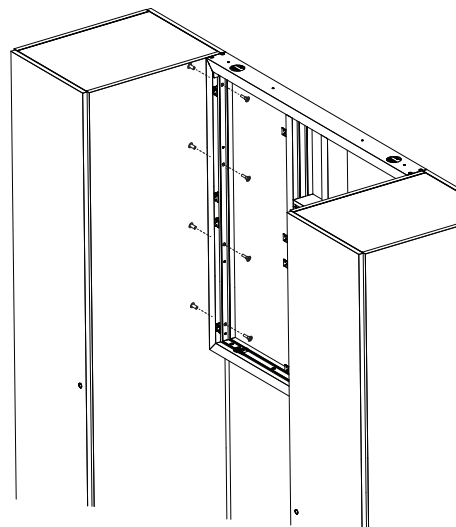

Figure C



2

Media Wall to Vertical Storage

With the units in their user location, position the Media Wall frame flush to the top and back edge of the Vertical Storage unit. Using a power drill with a 1/4" drill bit use the large holes in the Media Wall frame as a guide to bore through the panel of the Vertical Storage unit. Repeat process for the other side. **Note:** It is recommended (2) two or more individuals be used for this step. It is recommended that a scrap piece of wood be used to support the panel where the drill bit will bore through (Figure B).

3

Align connecting holes in the Vertical Storage to the Media Wall frame. Attach together using four (4) connecting bolts per side. Insert one half (1/2) of a connector bolt into a connecting hole in the Vertical Storage unit, insert the other half into the match connecting hole of the Media Wall frame. Tighten all bolts securely with a Allen Wrench. Make sure both units are flush against each other with no gaps (Figure C). Repeat process for the other side.

Conference and Training Solutions Vertical Storage Media Wall Ganging

Recommended Tools

- Power Drill
- Phillips Screw Bit
- 1/4" Drill Bit
- Allen Wrench

Package Contents	Qty.
#8 x 1 1/4" PH Screws	8
1/4" x 20 x 2" Connecting Bolts	8

NATIONAL | Furniture with Personality™

Telephone 800.482.1717
Fax 812.482.8800
www.nationalofficefurniture.com

Part #2141931
Rev,-

Printed in U.S.A
© 2008 Kimball International, Inc.