

**1**

## Media Wall to Vertical Storage

With the units in their user location, position the Media Wall frame flush to the top and back edge of the Vertical Storage unit. Using a power drill with a 1/4" drill bit use the large holes in the Media Wall frame as a guide to bore through the panel of the Vertical Storage unit. Repeat process for the other side. **Note:** It is recommended (2) two or more individuals be used for this step. It is recommended that a scrap piece of wood be used to support the panel where the drill bit will bore through (Figure A).

Figure A

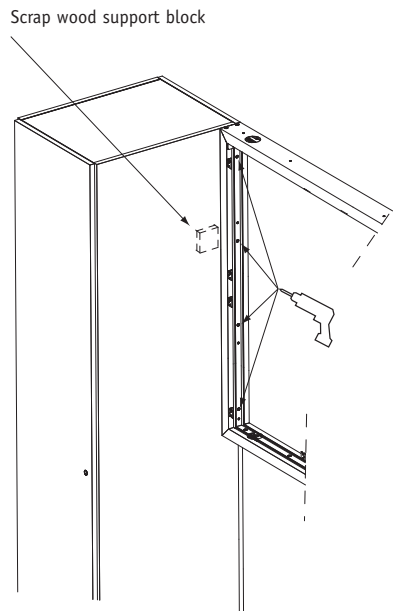

**2**

Align connecting holes in the Vertical Storage to the Media Wall frame. Attach together using four (4) connecting bolts per side. Insert one half (1/2) of a connector bolt into a connecting hole in the Vertical Storage unit, insert the other half into the match connecting hole of the Media Wall frame. Tighten all bolts securely with a Allen Wrench. Make sure both units are flush against each other with no gaps (Figure B). Repeat process for the other side.

Figure B

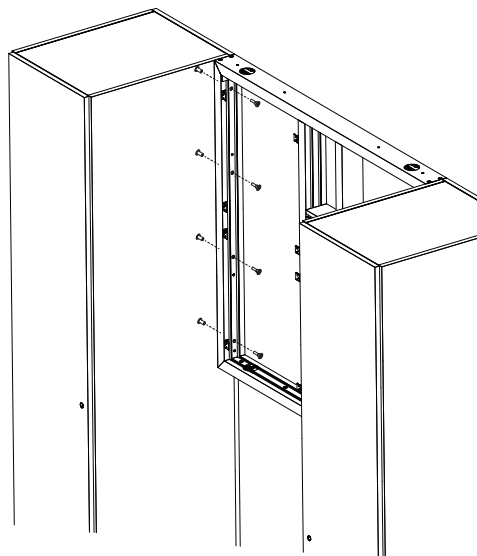

## Conference and Training Solutions Media Wall Ganging

### Recommended Tools

- Allen Wrench
- Power Drill with 1/4" Bit

Package Contents	Qty.
Media Wall	
• 1/4" x 20 x 2" Connecting Bolts	8

**NATIONAL** | Furniture with Personality™

Telephone 800.482.1717  
Fax 812.482.8800  
www.nationalofficefurniture.com

Part #2141528  
Rev,-

Printed in U.S.A  
© 2008 Kimball International, Inc.

## Assembly Instructions

### Media Wall Ganging

# Large Swing Mount Assembly and Installation

## Parts

3/8"- 24 x 5/8" Socket  
Button Head Cap Screws

1/4" -28 x 1/2" Socket  
Head Cap Screws

1" O.D. Steel  
Washer

Fastener Kit



(1) Vertical Base  
Sub Assembly

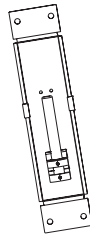

(1) Swing Arm  
Sub Assembly

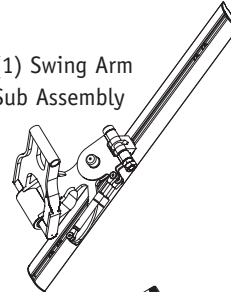

(1) Gas Shock

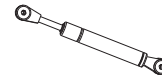

(1) Upper Swing  
Knuckle



(2) Vertical  
Panel Rails



(4) Wall Hooks



### Package Contents

#### Large Swing

- (12) 3/8"- 24 x 5/8" Socket Button Head Cap Screws
- (2) 1/4" -28 x 1/2" Socket Head Cap Screws
- (1) 1" O.D. Steel Washer
- (1) Vertical Base Sub Assembly
- (2) Horizontal Wall Tracks
- (1) Swing Arm Sub Assembly
- (2) Vertical Panel Rails
- (4) Wall Hooks
- (1) Gas Shock
- (1) Upper Swing Knuckle

**Note:** The Vertical Base Sub Assembly will be attached to the Media Wall at shipment. For interpretation it will be shown un-attached to the Media Wall in these Instructions.

# 1

### Install Vertical Display Rails

Select the most appropriate hardware for your Flat Panel from the fastener kit. Apply both vertical display rails to the rear of the Flat Panel, making sure that the affixed tabs are facing down as shown in (Figure F). **Note:** Vertical panel rails should be equally spaced up and down.

Figure F

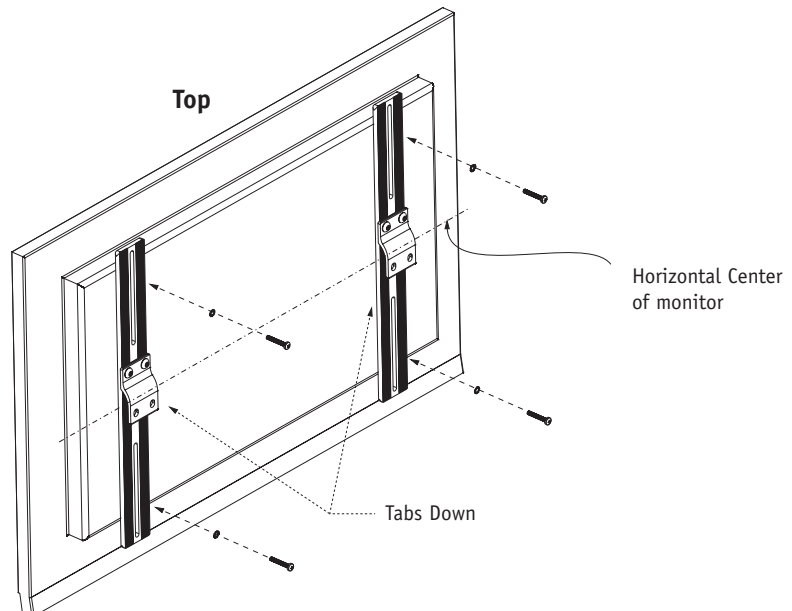

## Assembly Instructions

### Media Wall Ganging

2

#### Attaching the Swing Arm Sub Assembly

Remove the tape from the washer as shown in (Figure G). Slide the Swing Arm Sub Assembly onto the exposed shaft until it rests on the aforementioned washer. Slide the loose 1" O.D. washer onto the shaft, as shown in (Figure G).

Figure G

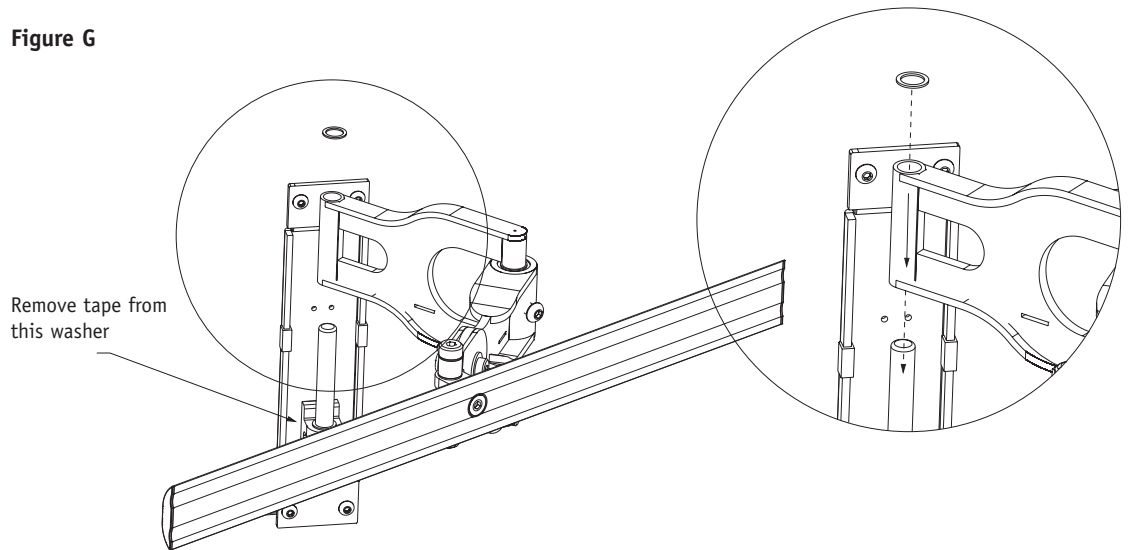

3

#### Hang the Panel

Lift the Flat Panel and hood the vertical panel rails over the horizontal track on the swing arm sub Assembly as shown in (Figure H), equally spaced.

Figure H

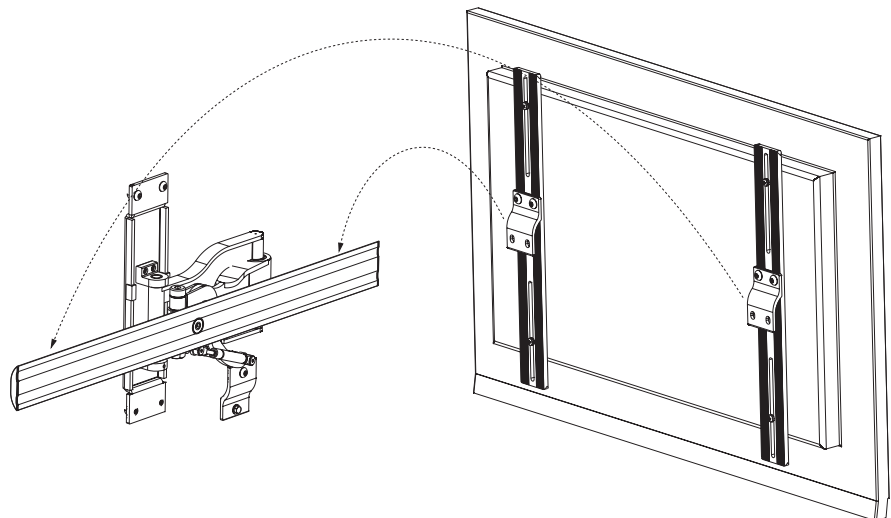

## Assembly Instructions

### Media Wall Ganging

4

#### Secure the Display

Using the provided 7/32" hex wrench, fasten four (4) 3/8"-24 x 5/8" socket screws into the pocketed 3/8" hex nuts, as shown in (Figure I). **Note:** Make sure all four (4) screws are securely fastened.

Figure I

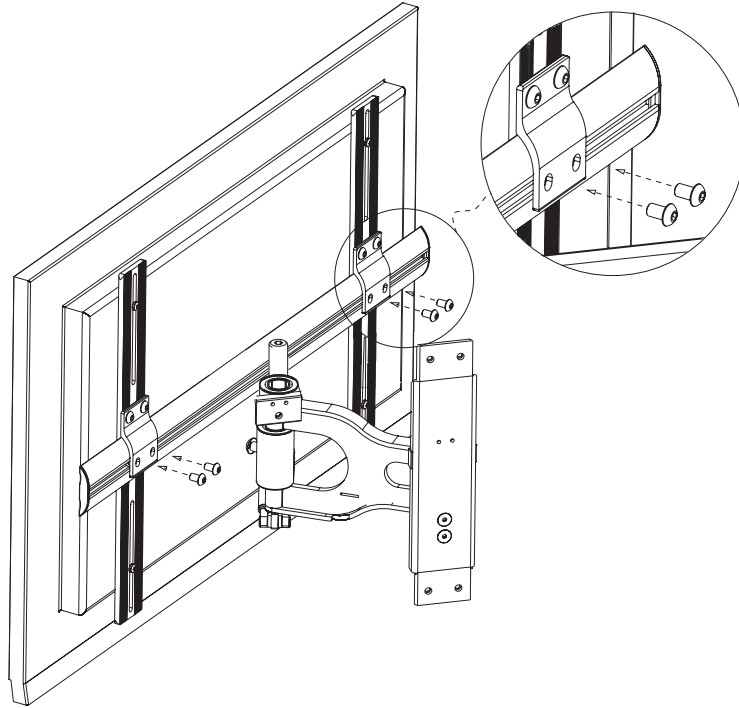

5

#### Finishing the Swing Arm

Slide the upper swing knuckle over the vertical base shaft as shown in (Figure J). Fasten two (2) 1/4"-28 x 1/2" socket head cap screw through the upper swing knuckle and onto the main vertical base.

Figure J

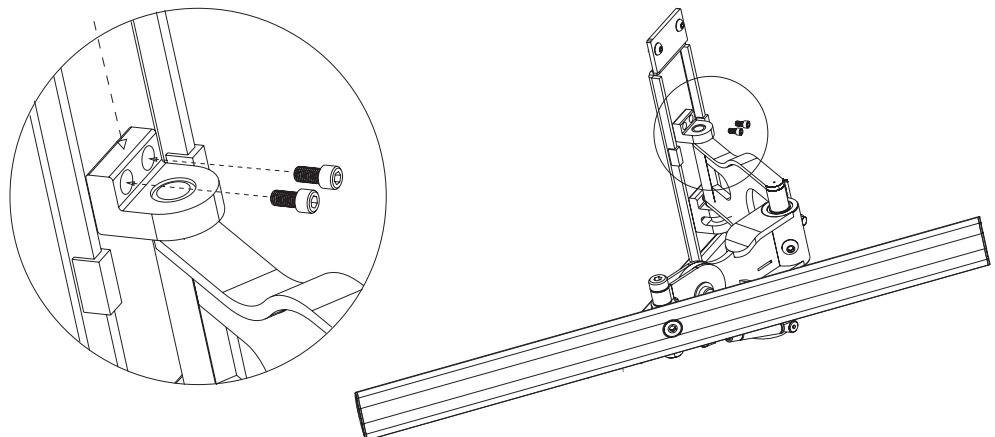

## Assembly Instructions

### Media Wall Ganging

**6**

#### For panels over 90 LBS

Use a 5mm hex wrench, to remove two (2) flange screws as shown in (Figure K). Remove all three (3) noted Nylon washers, replace washer with Gas Shock. Reinstall flange screws.

Figure K

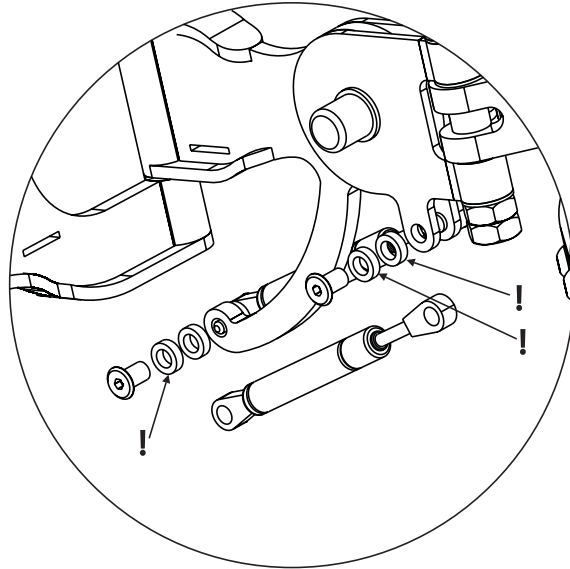

**7**

#### Display Adjustments

Adjust the flat panel unit by grasping the outer frame of the display and positioning it to suit your viewing angle.

Figure L

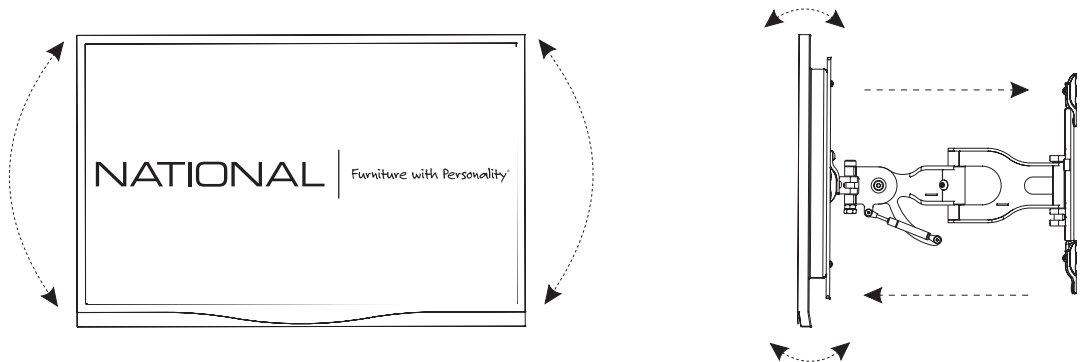

Proper product installation, in accordance with these instructions, is the responsibility of the installing agent. If you have any questions concerning these instructions, please call National Customer Care Teams.

# Assembly Instructions

## Media Wall Ganging

# Large Tilt Mount Assembly and Installation

## Parts

### Package Contents

#### Large Tilt

- (6) 3/8"- 24 x 1/2" Socket Button Head Cap Screws
- (4) #10-28 x 3/8" Socket Head Cap Screws
- (8) 3/8"-24 x 5/8" Socket Button Head Cap Screws
- (1) Bag Misc. Mounting Hardware
- (2) Interface Brackets
- (1) Horizontal Tilt Tracks
- (2) Vertical Display Rails
- (1) Vertical Display Rails

#10-24 x 3/8" Socket Head Cap Screws



3/8"- 24 x 1/2" Socket Button Head Cap Screws



3/8"- 24 x 5/8" Socket Button Head Cap Screws



Fastener Kit



(1) Horizontal Tilt Track

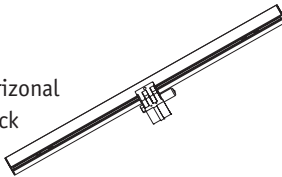

(2) Interface Brackets



(2) Vertical Display Rails



(1) Vertical Tilt Mount

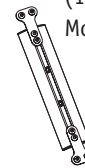

**Note:** The Vertical Tilt Mount will be attached to the Media Wall at shipment. For interpretation it will be shown un-attached to the Media Wall in these Instructions.

# 1

## Prepare Tilt

Using Four (4) #10-24 x 3/8" cap screws, attach the two (2) interface brackets to the base knuckle of the Horizontal Tilt Track. Tighten with a 5/32" Hex Wrench (Figure M).

Figure M

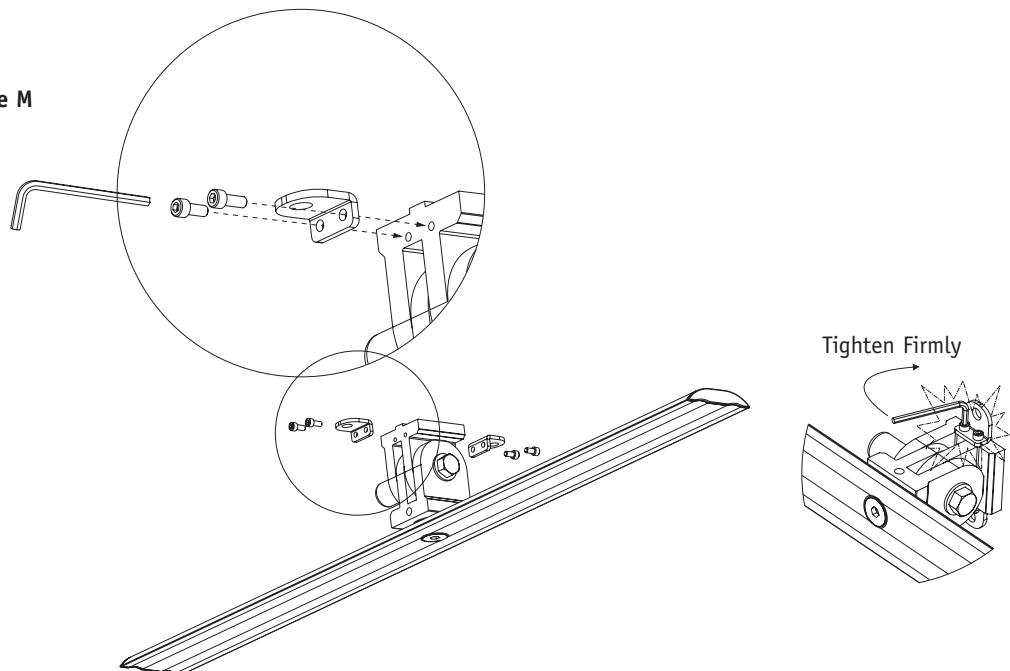

## Assembly Instructions

### Media Wall Ganging

## 2

### Assemble the Tilt Sub Assembly

Use a 7/32" Hex Wrench to thread two (2) 3/8"-24 c 1/2" Socket Button Head Cap Screws through the installed Interface Brackets and into the Hex nuts pocketed inside the Vertical Tilt Track. Insure the Boss on the Knuckle is aligned and seated in the Pocket. Center and Tighten (Figure N).

Figure N

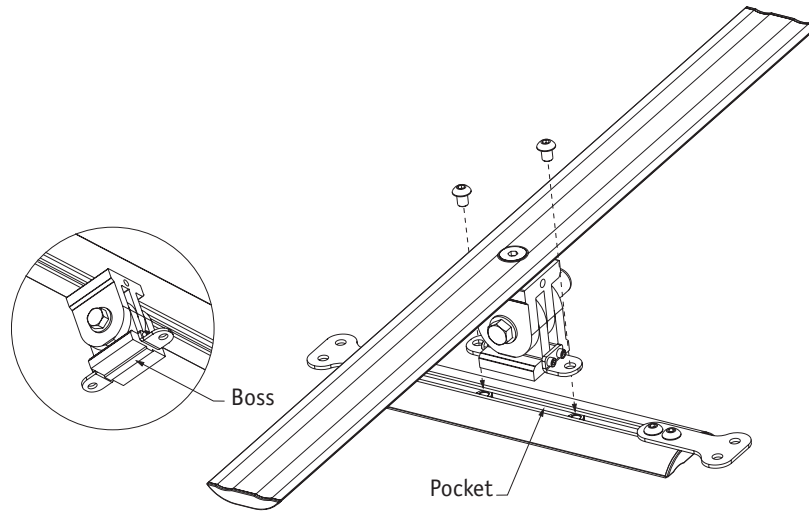

## 3

### Install Vertical Display Rails

Select the most appropriate hardware for your Flat Panel from the fastener kit. Apply both vertical display rails to the rear of the Flat Panel, making sure that the affixed taps are facing down as shown in (Figure F). **Note:** Vertical panel rails should be equally spaced and down.

Figure O

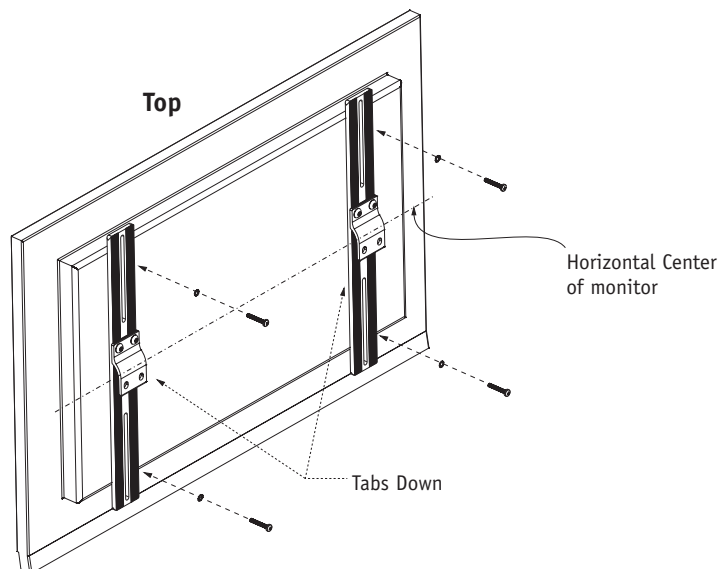

## Assembly Instructions

### Media Wall Ganging

#### 4

#### Pre-Panel Hanging Adjustments

Some Adjustments may be made before hanging the panel Sub Assembly onto the tilt mount. A vertical adjustment may be made by loosening the two (2) screws indicated (Figure A) and raising or lowering the Horizontal track 5 1/2 inches of travel. Make sure all screws are securely tightened before continuing to the next step, reference (Figure P).

Figure P

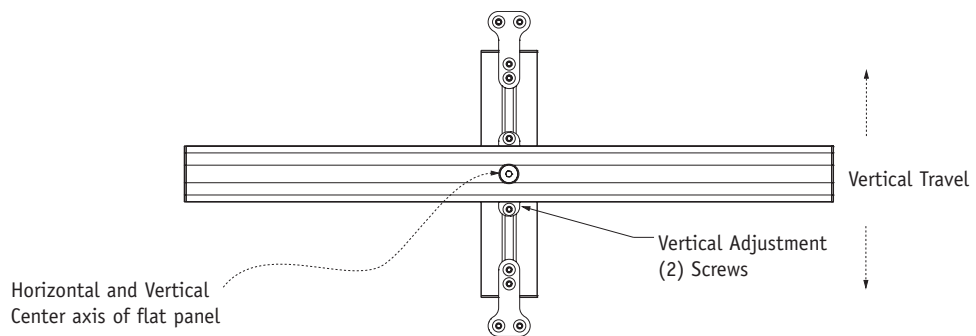

#### 5

#### Hang the Panel

Before Lifting the Panel, insure the hooks on the Vertical Display Rails are pointed downward as shown in (Figure Q). Hook the panel Sub Assembly over the Horizontal Bar and center on the Horizontal Tilt Track.

Figure Q

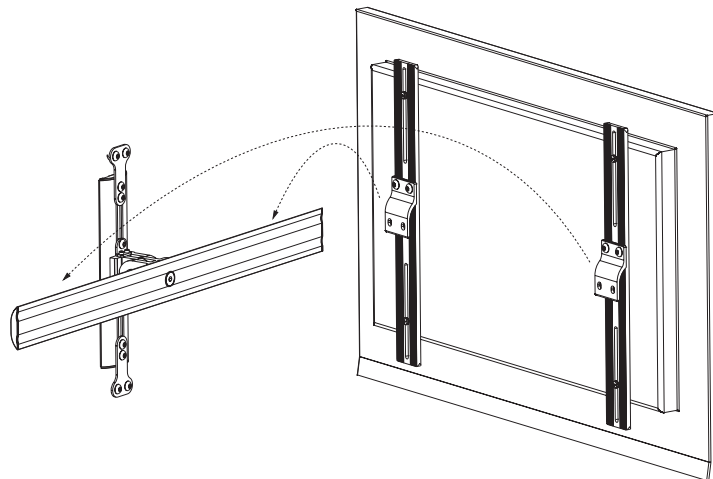

## Assembly Instructions

### Media Wall Ganging

6

#### Secure the Panel

Use a  $7/32$ " Hex Wrench, install four (4)  $3/8$ "-24 x  $5/8$ " Socket Button Head Cap Screws through Hooks and into Pocketed  $3/8$ "-24 Hex Nuts, secure tightly (Figure R).

Figure R

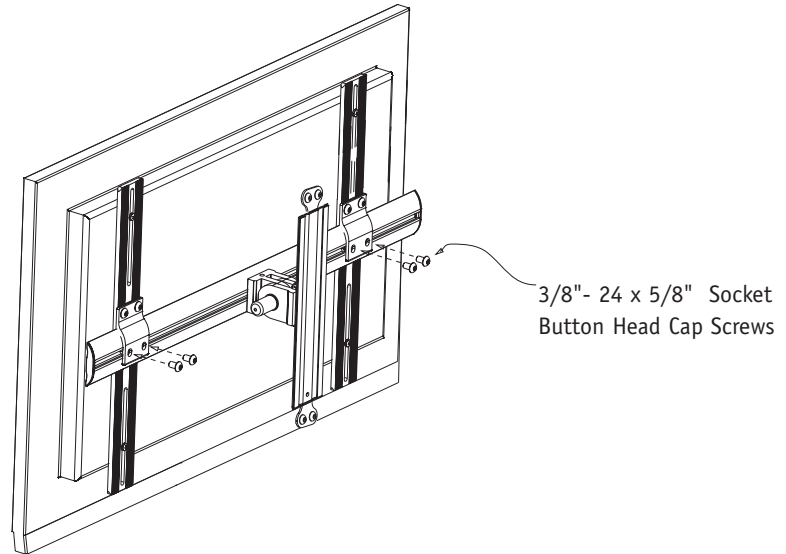

7

#### Level and Tilt the Display

Level the Panel by grasping each side and adjusting. Tilt the Panel by grasping the Top and Bottom and adjusting (Figure U).

Figure U

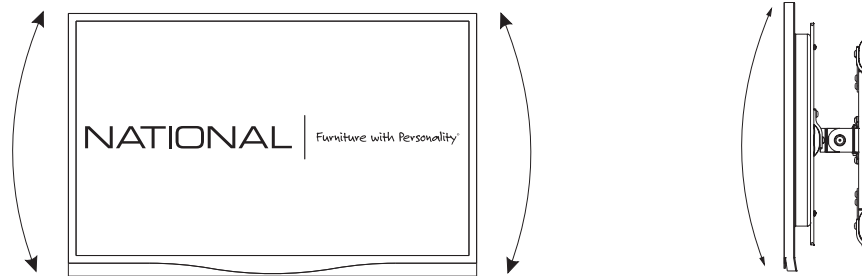

Proper product installation, in accordance with these instructions, is the responsibility of the installing agent. If you have any questions concerning these instructions, please call National Customer Care Teams.