

Myriad™ Glass Kit

Recommended Tools

- Power Drill
- 3/8" Drill Bit
- No.#2 Lead Pencil
- Square
- Masking Tape

Package Contents	Qty.
• Glass Kit	1
• 5/16"-18 x 1 1/2" Threaded Inserts	4

1

Screw in by hand, the (4) threaded inserts into the stanchions attached to the glass top (Figure A).

Figure A

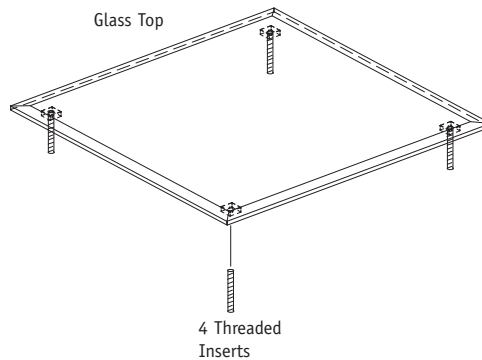

2

Locate the (4) prebored holes on the underside of the unit's work surface. With a power drill and a 3/8" drill bit, bore through the work surface using the prebored holes as a guide.

NOTE: It is recommended that a scrap block of wood be used to support where the drill bit will bore through.

Figure B

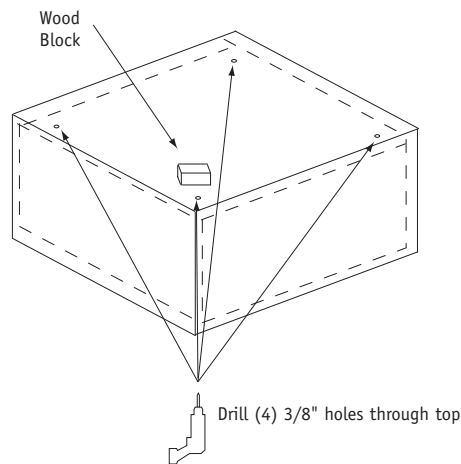

3

Note: Step #3, Figure C is for the Console Table only. It is bored from the face side down.

Place masking tape over the position of the boring shown in Figure C. With a Number 2 pencil, mark a line on the masking tape matching the measurements in Figure C. Use a power drill with a 3/8" drill bit, to bore through the work surface. Repeat process on each of the 4 corners.

Figure C **Note:** Console Table only

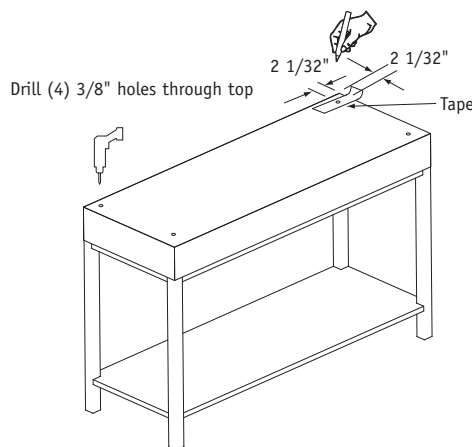

4

Position the 4 inserts of the glass top into the 4 bored holes of the work surface.

NATIONAL Furniture with Personality

Telephone 800.482.1717
 Fax 812.482.8800
 www.nationalonline.com

Part #2106926
 Rev. -

Printed in U.S.A
 © 2008 Kimball International, Inc.

Proper product installation, in accordance with these instructions, is the responsibility of the installing agent. If you have any questions concerning these instructions, please call National Customer Service.