

Myriad™ Training Electric Table

Recommended Tools

- 6mm Allen Wrench
- 5mm Allen Wrench
- 4mm Allen Wrench
- Square

Package Contents	Qty.
• M8 x 20 CH screw	2
• M6 x 10 CH screw	12
• M6 x 10 FH screw	4

1

Install two (2) M8 x 20mm screws 2-3 turns into the small bracket at the side of the bottom tube of each leg. Insert the cross tube and slide it with the keyhole over the screws (Figure A).

Figure A

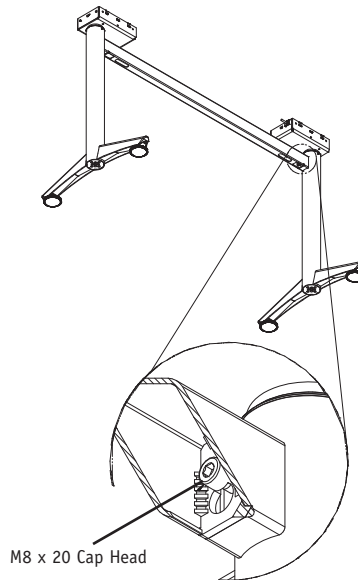

2

Attach the 2 long cross bars to the chromed motor housing using twelve (12) M6 x 10mm screws, hand tighten. Slide the two (2) top support bars into the cutout of the cross bar, attach using four (4) FH M6 x 10mm screws. Use a square to position the legs 90 degrees to the cross bar, tighten screws (Figure B).

Figure B

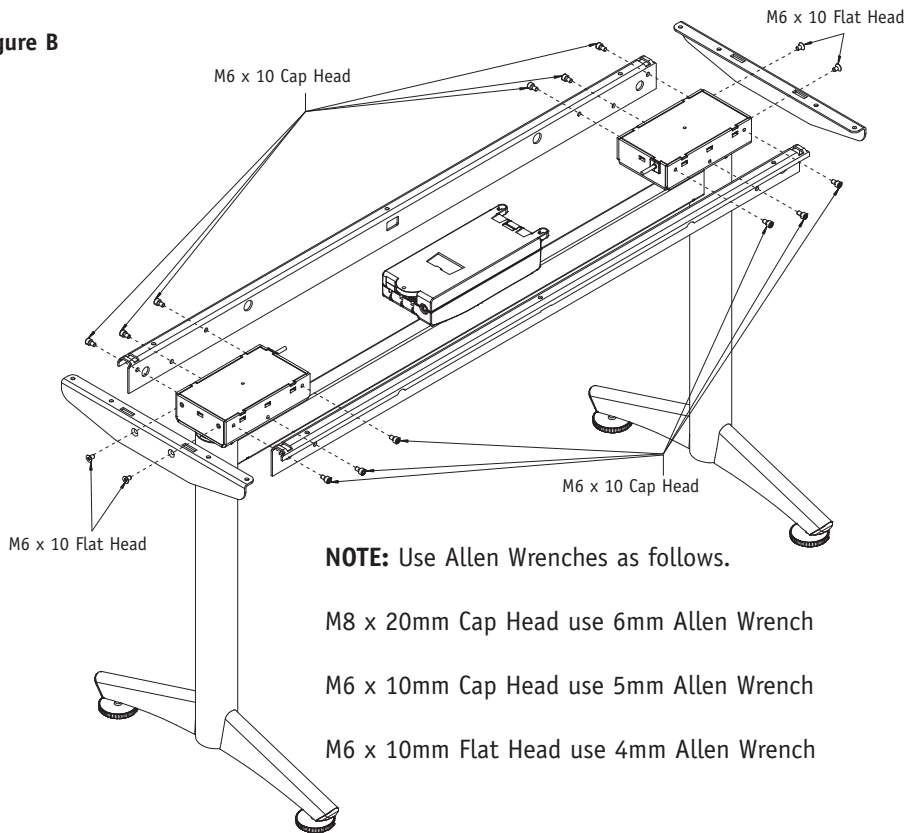

NOTE: Use Allen Wrenches as follows.

M8 x 20mm Cap Head use 6mm Allen Wrench

M6 x 10mm Cap Head use 5mm Allen Wrench

M6 x 10mm Flat Head use 4mm Allen Wrench

3

Plug motorcables and handswitch into control box, connect power cable. Press the **Down** button for approx. 6 seconds to initialize the system. **Note:** Table may slightly move up and down, that's normal. Keep button pressed until moving stops.

Proper product installation, in accordance with these instructions, is the responsibility of the installing agent. If you have any questions concerning these instructions, please call National Customer Service.