

**Barrington 5000
Task Return**

Note: This instruction explains installation of a task return to a desk. It is recommended that more than one person be used to assemble this unit. It is also recommended that the desk be in its intended location prior to attachment of the return.

1

Remove plastic film backer from one side of the adhesive tape. Adhere tape to the return's modesty panel edge, covering the dowel holes (Figure A).

Figure A

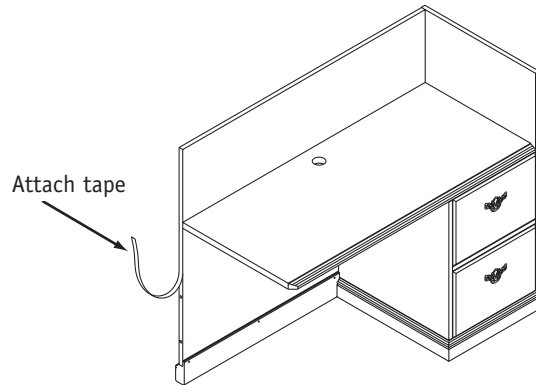

2

Cut tape away from dowel holes and insert dowels (Figure B).

Figure B

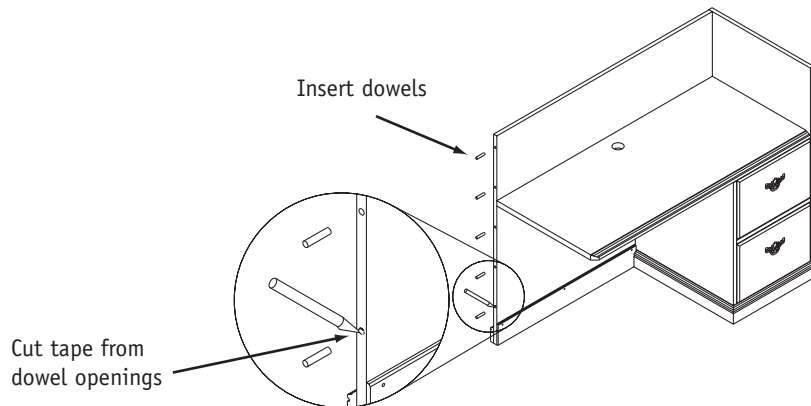

3

Attach two (2) mounting brackets to underside of desk top, centering the brackets with the edge of the top. Use four (4) #10 x 3/4" panhead screws per bracket (Figure C).

Figure C

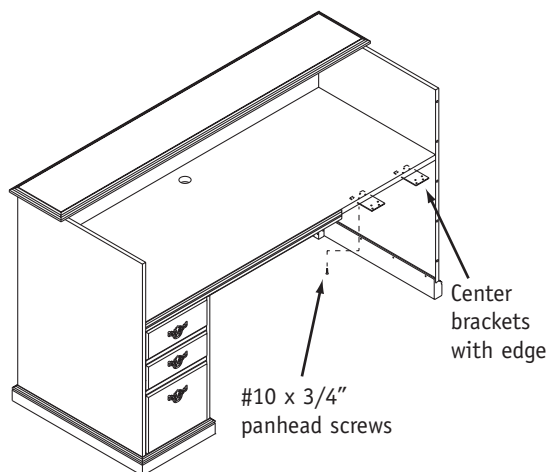

Recommended Tools

- Phillips Screwdriver
- Electric Drill
- Square

Package Contents

Qty.

- | | |
|-------------------------------|----|
| • Return | 1 |
| • Double Side Tape | 1 |
| • 3/8" x 1 1/2" Wooden Dowels | 6 |
| • Mounting Brackets | 4 |
| • #10 x 3/4" Panhead Screws | 32 |

NATIONAL

Furniture with Personality™

Telephone 800.482.1717
Fax 812.482.8800
www.nationalonline.com

Form #NAIBRTR
#1555486

Printed in U.S.A
© 2001 Kimball International, Inc.

Proper product installation, in accordance with these instructions, is the responsibility of the installing agent. If you have any questions concerning these instructions, please call National Customer Service.

**Barrington 5000
Task Return**

- 4** Attach two (2) mounting brackets to inside of edge of desk and end panel, centering the brackets with the edge of the end panel. Use four (4) #10 x 3/4" panhead screws per bracket (Figure D).

Figure D

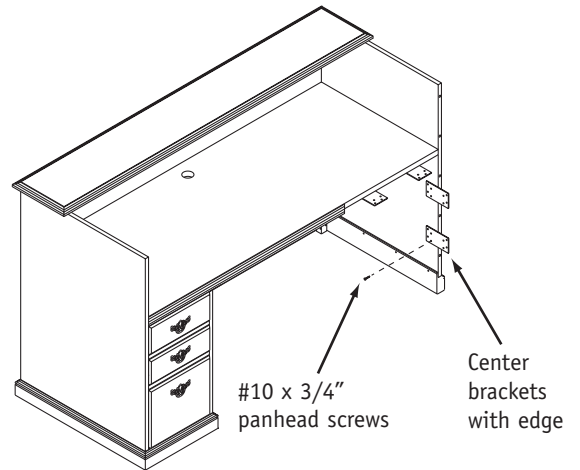

- 5** Remove remaining plastic film backing from adhesive tape on return. Align dowels in return with holes in desk. Push return towards desk, making sure dowels enter holes in desk. Make sure all worksurfaces and panels are flush, then press both unit firmly together to eliminate any gaps (Figure E).

Figure E

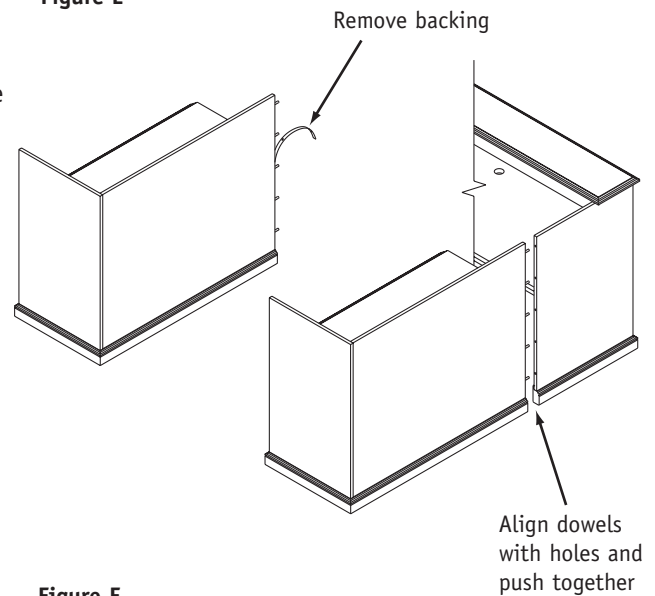

- 6** Attach all mounting brackets to the return using (16) #10 x 3/4" panhead screws. Make sure all gaps are eliminated and firmly tighten all screws (Figure F).

Figure F

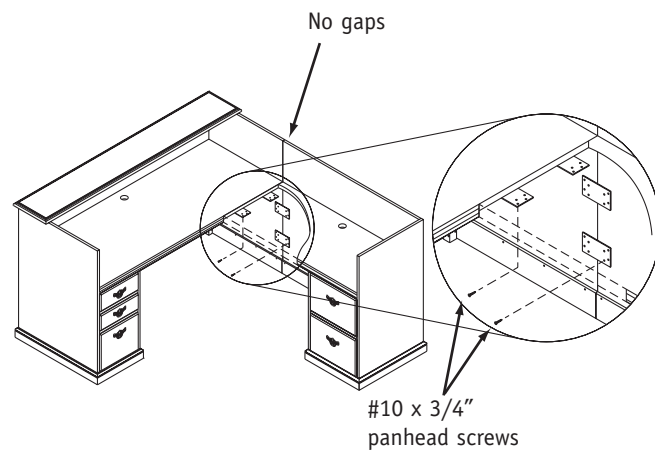

Proper product installation, in accordance with these instructions, is the responsibility of the installing agent. If you have any questions concerning these instructions, please call National Customer Service.