

Assembly Instructions

- 1** Carefully place highback upside down **Figure A** on a smooth, clean, soft surface. Remove eight (8) screws and two (2) triangle shipping pads. Sand bottom edges with a medium grit sandpaper (Figure A).

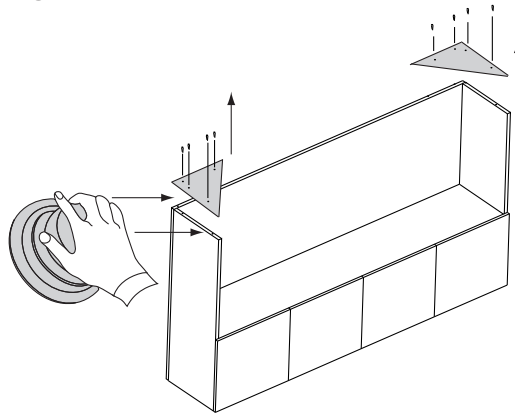

- 2** Attach double faced tape to the bottom of the highback's end and back panels (Figure B).

Figure B

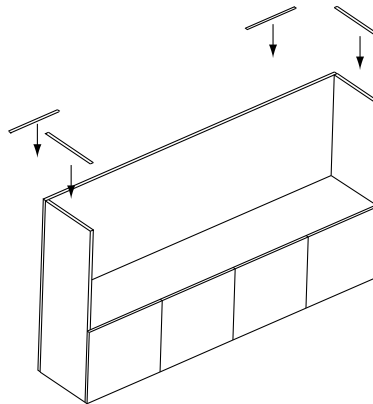

- 3** Set highback upright in it's final position. Remove protective backing from each piece of double faced tape. Press down to ensure good bond (Figure C).

Figure C

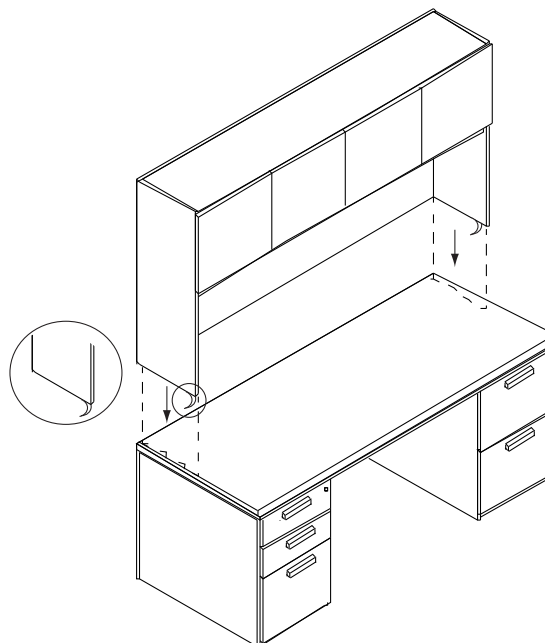

Note: The tape is a very strong adhesive and bonds instantly to the surface it is applied to.

Casbah™ Casegoods Highback Organizer

Recommended Tools

- Phillips Screw Driver
- Medium Grit Sandpaper

Package

Contents	Qty.
• Highback Organizer	1
• Double Faced Tape	

NATIONAL

Furniture with Personality®

Telephone 800.482.1717
Fax 812.482.8800
www.nationalonline.com

Part #2071192

Printed in U.S.A
© 2007 Kimball International, Inc.

Proper product installation, in accordance with these instructions, is the responsibility of the installing agent. If you have any questions concerning these instructions, please call National Customer Care Teams.

Assembly Instructions

Casbah™ Casegoods Highback Organizer

4

Glass Door Installation

Install top hinge on mounting plate, locate the pins on the mounting plate into the recesses on the under side of the hinge arm as shown in (Figure D).

With the front of the hinge arm fully seated, press on the back of the hinge arm until the arm “snaps” and is locked into position (Figure F).

Repeat step Four (4) for every glass door.

Figure D

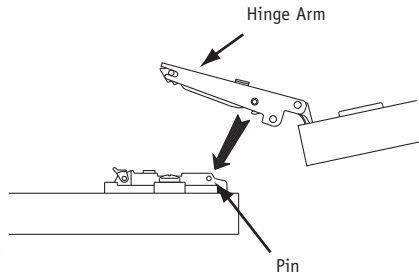
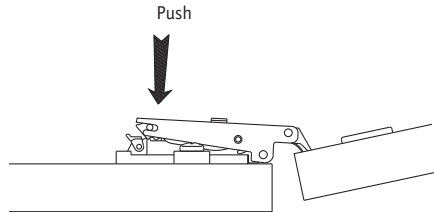

Figure F



Proper product installation, in accordance with these instructions, is the responsibility of the installing agent. If you have any questions concerning these instructions, please call Kimball Customer Care Teams.