

Note: Instructions are for 14", 17" and 22" keyboard mounting plates.

1

Insert two (2) #12 x 3/4" panhead screws into pilot holes of large spacer pad (Figure A).

Note: Leave 1/8" gap between the spacer pad and the flat surface of the screw head (Figure A).

Figure A

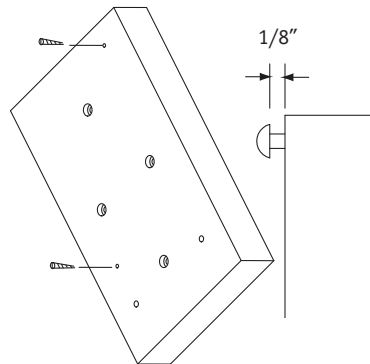

2

Attach small spacer pad to back edge of keyboard mounting plate with two (2) #12 x 3/4" panhead screws. Align back and side edge of spacer pad with keyboard mounting plate (Figure B).

Figure B

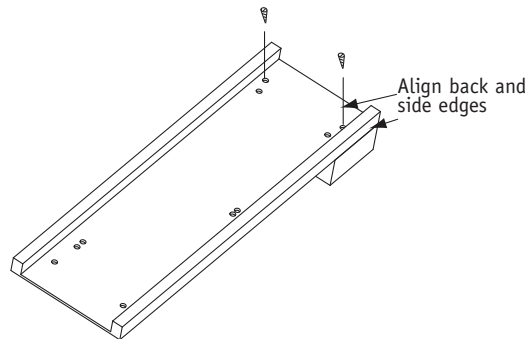

Casbah™ Casegoods Keyboard Mounting Plate

Recommended Tools

- Screw Gun
- Phillips Head Bit
- Square

| Package Contents | Qty. |
|-------------------------------|------|
| • Large Spacer Pad | 1 |
| • Small Spacer Pad | 1 |
| • #12 x 3/4" Panhead Screws | 4 |
| • #10 x 2 1/4" Panhead Screws | 8 |

NATIONAL

Furniture with Personality™

Telephone 800.482.1717
Fax 812.482.8800
www.nationalonline.com

Part #2071191

Printed in U.S.A.
© 2007 Kimball International, Inc.

Proper product installation, in accordance with these instructions, is the responsibility of the installing agent. If you have any questions concerning these instructions, please call National Customer Care Teams.

Assembly Instruction

Casbah™ Casegoods Keyboard Mounting Plate

- 3** Attach large spacer pad to the bottom of desk worksurface with four (4) #10 x 2 1/4" panhead screws. Align large spacer pad to façade rail (Figure C).

Note: Left or right placement is per users discretion.

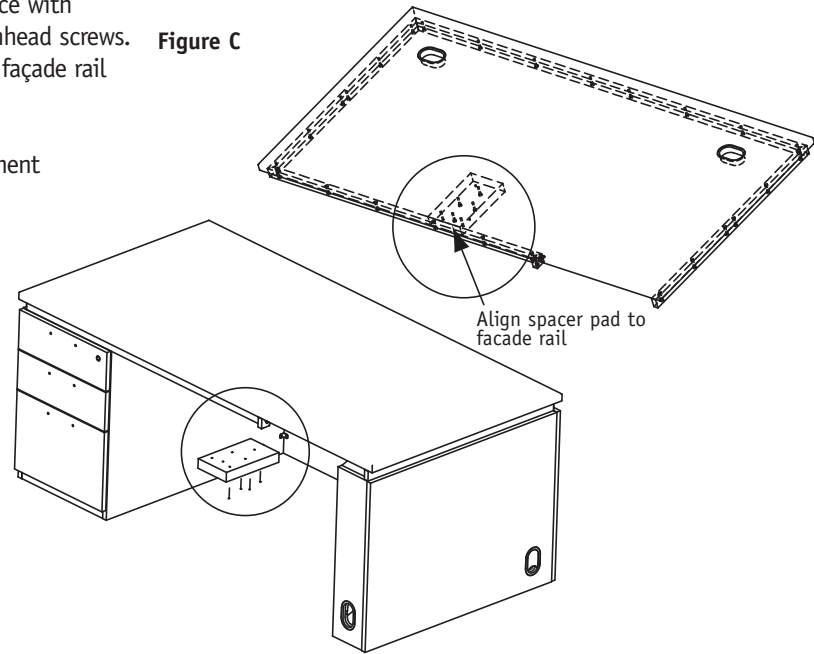

- 4** Slide keyboard mounting plate onto the extended screws of the larger spacer pad, through the keyholes. Tighten screws, Install four (4) #10 x 2 1/4" panhead screws (Figure D).

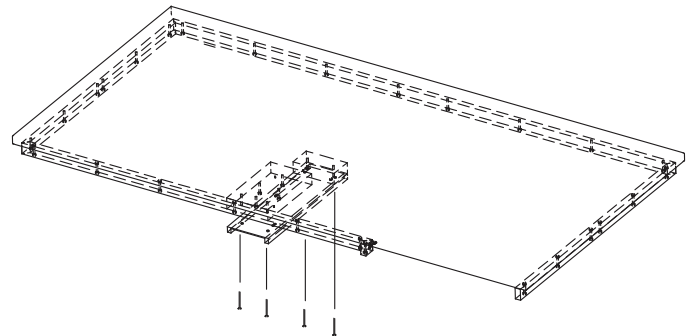

Proper product installation, in accordance with these instructions, is the responsibility of the installing agent. If you have any questions concerning these instructions, please call National Customer Care Teams.