

1

Install glides four (4) per pedestal. Attach two (2) mounting brackets to the under side of the transaction desk where the worksurfaces will meet. Center the brackets with the edge of the worksurface. Attach each bracket with four (4) #10 x 1" panhead screws (Figure A).

Figure A

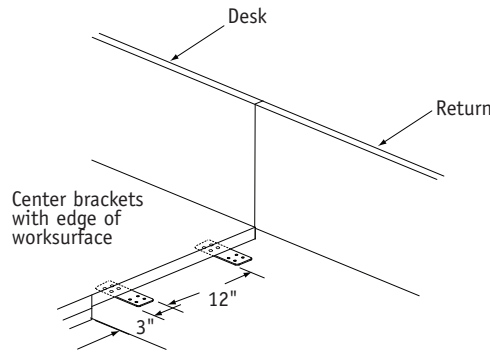

2

Attach metal L brackets to the modesty panel of the return with three (3) #8 x 5/8" panhead screws. With reception desk in its desired location, **Level** and align return with desk. Make sure all panels and worksurfaces are flush. Press units firmly together to eliminate all gaps. Attach metal L brackets to the Pedestal panel of the Desk with three (3) #8 x 5/8" panhead screws (Figure B).

Figure B

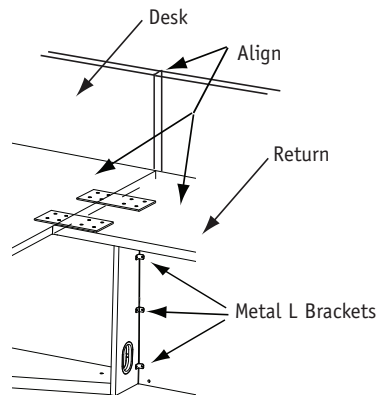

3

NOTE: If needed to align recessed façade on return, loosen first screw in façade and adjust alignment to desk façade so faces are flush re-tighten screw (Figure C).

Figure C

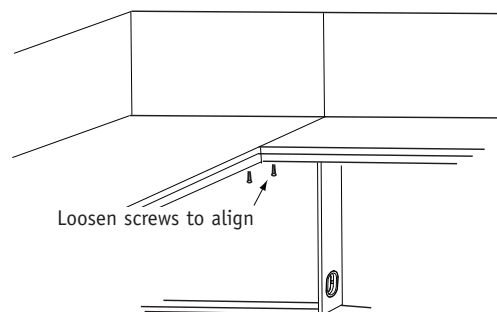

Casbah™ Casegoods Reception Desk and Return

Recommended Tools

- Screw Gun
- Phillips Head Bit
- Square
- Level

Package Contents Qty.

Package Contents	Qty.
Contents for use of Return	
• Return	1
• Mounting Brackets	2
• #10 x 1" Panhead Screws	16
• #8 x 5/8" Panhead Screws	6
• L Brackets	3

NATIONAL

Furniture with Personality™

Telephone 800.482.1717
 Fax 812.482.8800
 www.nationalonline.com

Part #2071193

Printed in U.S.A.
 © 2007 Kimball International, Inc.

Proper product installation, in accordance with these instructions, is the responsibility of the installing agent. If you have any questions concerning these instructions, please call National Customer Care Teams.