

CINCH Tablet Arm

1

Turn chair over on back with bottom of seat facing you (Figure A).

Figure A

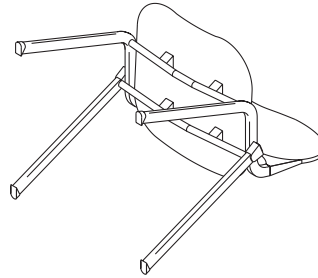

2

Place the top bracket between the seat and the frame. The bracket has an arrow facing downward.

Place the bottom bracket below the chair seat frame. The bracket has an arrow facing upward. Join the two brackets together with two (2) M8x35mm Allen screws and washers (do not tighten it).

Adjust the two brackets to the extreme outside left (if right-handed), right (if left-handed). Figure B.

Figure B

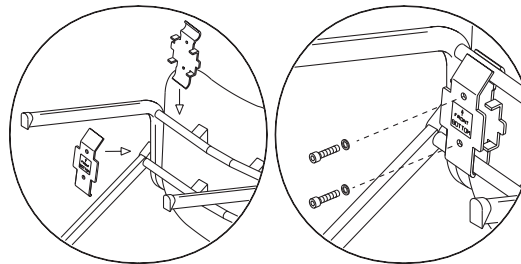

3

Insert the V-shaped arm in between the two brackets until the V-shaped arm support's bottom two round knobs touch the left (right) side of the bottom bracket. Tighten the bracket with a 6mm Allen wrench (Figure C).

Place chair in upright position.

Figure C

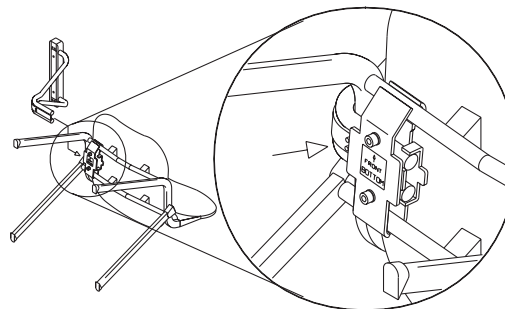

4

Attach the P-shaped writing tablet to the V-shaped using the four (4) M6x12mm Allen screws and a 4mm Allen wrench (Figure D).

Figure D

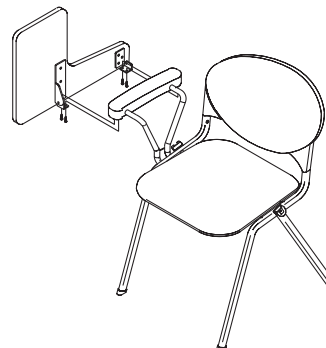

Recommended Tools

- 6mm Allen wrench
- 4mm Allen wrench

Package Contents

Per Chair	Qty.
• M8x35mm Allen screws	2
• M6x12mm Allen screws	4
• Washers	2
• Mounting Brackets	2
• P-shaped Tablet	1
• V-shaped Armrest	1

NATIONAL

Furniture with Personality™

Telephone 800.482.1717

Fax 812.482.8800

www.nationalonline.com

Form #NAICTA

© 2002 Kimball International, Inc.

Proper product installation, in accordance with these instructions, is the responsibility of the installing agent. If you have any questions concerning these instructions, please call National Customer Service.