

Bullet Unit

Note: Construct this unit upside down.

1 Place worksurface face down on a smooth, hard surface. Attach cylinder leg (ordered separately) by lining up base plate holes with pre-bored holes on bottom side of worksurface (Figure A).

Figure A

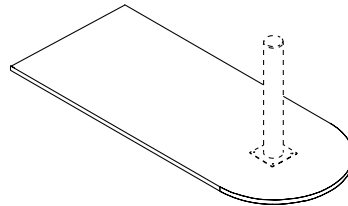

2 Attach (4) L-Brackets to top of end panel using (8) 5/8" pan head screws. Tops of all L-Brackets should be 1/32" below edge of panel (Figure B).

Figure B

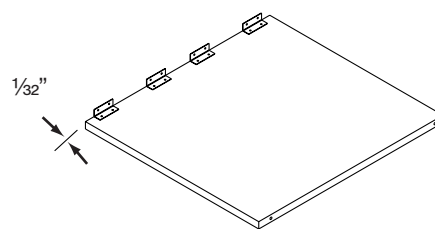

3 Attach end panel to underside of worksurface using (8) 5/8" pan head screws. Recess back panel 3/32" on sides and end of worksurface (Figure C).

Figure C

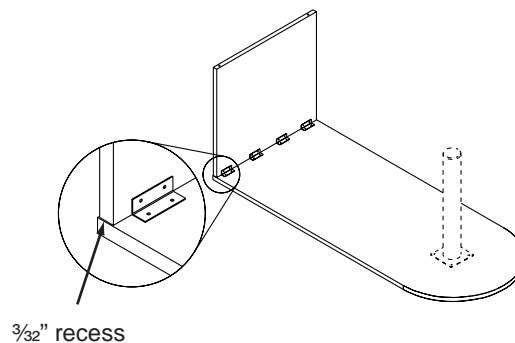

Recommended Tools

- Tape Measure
- Drill
- Phillips Screw Bit
- Square
- Level

Package Contents

	Qty.
• Worksurface	1
• End Panel	1
• Support Panel	1
• T-Bracket	1
• L-Brackets	8
• 1 1/2" Flat Head Screws	5
• 5/8" Pan Head Screws	32

NATIONAL

Furniture with Personality™

Telephone 800.482.1717
 Fax 812.482.8800
www.furniture.kimball.com/nof

Form #NAIENVBU-01
 #1471560

Printed in U.S.A
 © 2001 Kimball International, Inc.

Proper product installation, in accordance with these instructions, is the responsibility of the installing agent. If you have any questions concerning these instructions, please call National Customer Care Teams.

Bullet Unit

4 Attach (4) L-Brackets to support panel at locations shown in Figure D using $\frac{5}{8}$ " screws. Brackets should be $\frac{1}{32}$ " off edges of panel (Figure D).

Figure D

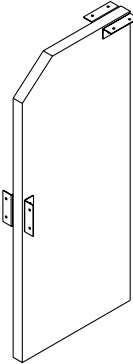

5 Attach support panel to end panel and worksurface with remaining $\frac{5}{8}$ " screws. Make sure support panel is centered (Figure E).

Figure E

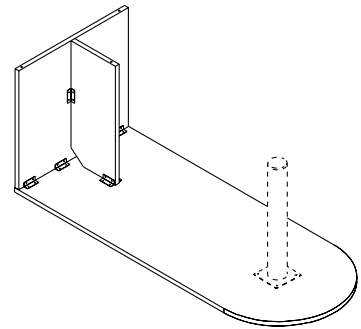

6 Square support panel and attach T-Bracket to end panel and support panel using (5) $1\frac{1}{2}$ " flat head screws (Figure F).

Figure F

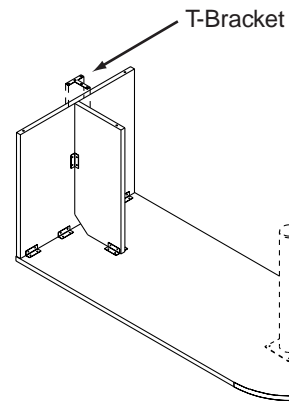

7 Tighten all screws securely. Insert leg levelers. Carefully turn unit upright, then level unit (Figure G).

Figure G

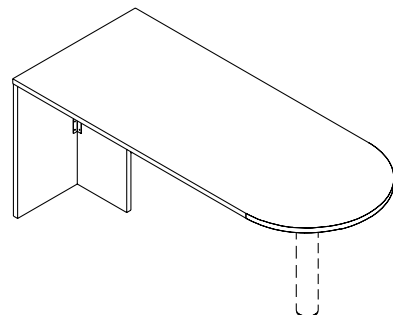

Proper product installation, in accordance with these instructions, is the responsibility of the installing agent. If you have any questions concerning these instructions, please call National Customer Care Teams.