

**CRT**

**Note:** Construct this unit upside down.

**Note:** This is not a freestanding unit.

**1** Place largest panel face down on a smooth, hard surface. Attach L-Brackets as shown in Figure A using the  $\frac{5}{8}$ " pan head screws. Tops of L-Brackets must be  $\frac{1}{32}$ " below top edge of panel. The L-Bracket on the same end as the leveling glide must be 2" from the end. The L-Bracket on the other end must be  $\frac{1}{4}$ " from the end (Figure A).

**Figure A**

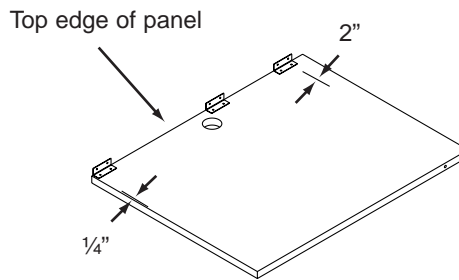

**2** Place shorter back panel face down on a smooth, hard surface. Attach L-Brackets as shown in Figure B using the  $\frac{5}{8}$ " pan head screws. Tops of L-Brackets must be  $\frac{1}{32}$ " below edge and side of panel. Take note to place one L-Bracket  $\frac{1}{4}$ " off rear edge of panel (Figure B).

**Figure B**

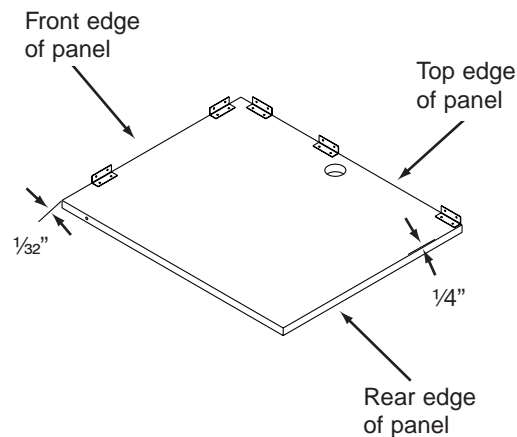

**3** Attach (4) L-Brackets to each support panel as shown in Figure C using the  $\frac{5}{8}$ " pan head screws. The L-Brackets must be  $\frac{1}{32}$ " off each edge (Figure C).

**Figure C**

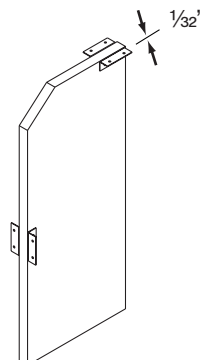

**Recommended Tools**

- Tape Measure
- Square
- Level
- Phillips Screw Bit
- Drill

**Package**

Contents	Qty.
• Back Panel (larger)	1
• Back Panel (smaller)	1
• Worksurface	1
• Support Panels	2
• L-Brackets	16
• Flat Brackets	4
• $\frac{5}{8}$ " Pan Head Screws	64
• $\frac{3}{4}$ " Screws	32

**NATIONAL**

Furniture with Personality™

Telephone 800.482.1717

Fax 812.482.8800

www.furniture.kimball.com/nof

Form #NAIENVCRT-01

#1284665

Printed in U.S.A

© 2001 Kimball International, Inc.

Proper product installation, in accordance with these instructions, is the responsibility of the installing agent. If you have any questions concerning these instructions, please call National Customer Care Teams.

**CRT**

- 4** Place worksurface upside down on a smooth, hard surface (Figure D).

**Figure D**

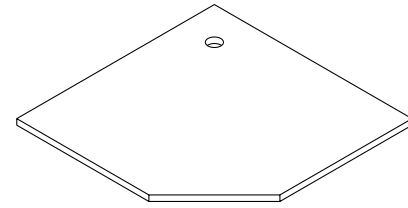

- 5** Attach back panels to worksurface and each other as shown in Figure E using the  $\frac{5}{8}$ " pan head screws. Make sure larger panel overlaps shorter panel. Worksurface should extend  $\frac{3}{32}$ " past panels on each side (Figure E).

**Figure E**

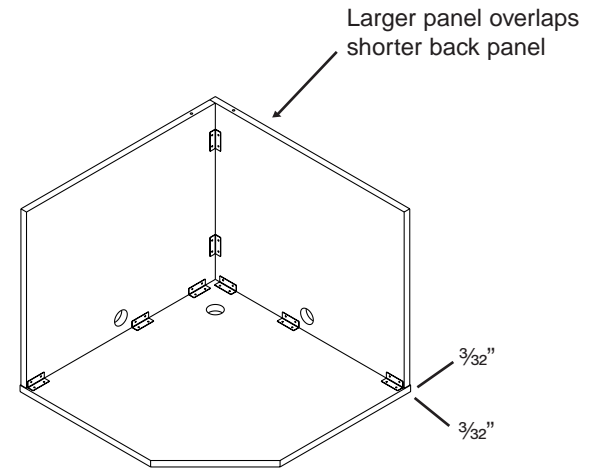

- 6** Attach the support panels to the worksurface and back panels as shown in Figure F using the  $\frac{5}{8}$ " pan head screws. Support panels must be recessed  $3\frac{1}{2}$ " from edge of top. Insert all leg levelers (Figure F).

**Figure F**

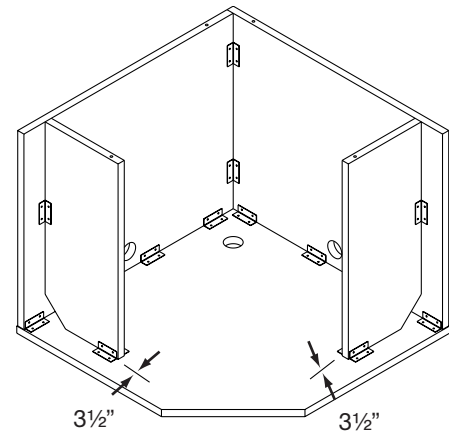

Proper product installation, in accordance with these instructions, is the responsibility of the installing agent. If you have any questions concerning these instructions, please call National Customer Care Teams.

**CRT**

**7**

Square up unit and tighten all screws securely. Carefully turn unit upright (Figure G).

**Figure G**

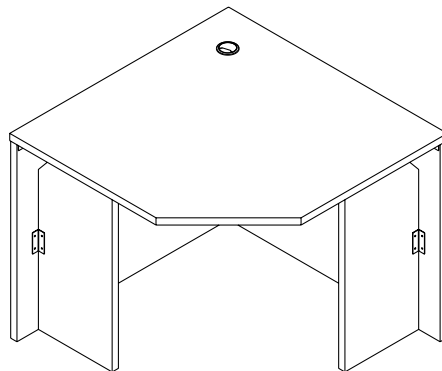

**8**

Prepare returns for attachment to CRT by first attaching (2) Flat Brackets (included with return) to the underside of the return work surface at locations shown in figure H using the  $\frac{3}{4}$ " screws, overlapping the work surface by half. Attach return mounting cleat (included with return) to each return at the location shown in Figure H using the  $1\frac{1}{8}$ " screws.

**Figure H**

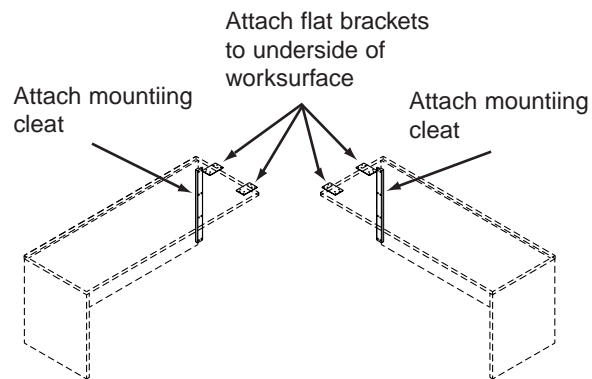

**9**

Slide return units into position next to CRT worksurface. Attach flat brackets to underside of CRT using  $\frac{3}{4}$ " screws. Make sure all surfaces are flush and attach mounting cleats to CRT back panels using  $\frac{3}{4}$ " screws. Level all units (Figure I).

**Figure I**

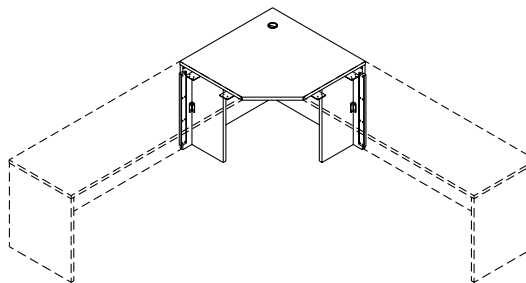

Proper product installation, in accordance with these instructions, is the responsibility of the installing agent. If you have any questions concerning these instructions, please call National Customer Care Teams.

# CASEGOODS

Assembly Instructions

**CRT**

Proper product installation, in accordance with these instructions, is the responsibility of the installing agent. If you have any questions concerning these instructions, please call National Customer Care Teams.