

Extended Corner Return (with either 1 or 2 recessed panels)

Recommended Tools

- Power Screwdriver
- Phillips Head Bit
- Hand-held Phillips

Package Contents	Qty.
• Worksurface	1
• End Panel	1
• Modesty Panel	1
• Small Support Panel	1 or 2
• Full Support Panel	1
• Threaded Stud	16
• L-Bracket	4 per small support panel
• 5/8" Screw	4 per L-bracket
• Return Mounting Cleat	1
• Mounting Cleat Screws	4 per cleat

NATIONAL
Furniture with Personality®

Telephone 800.482.1717
Fax 812.482.8800
www.nationalonline.com

Form #NAIEWECR
Part #1583406

Printed in U.S.A
© 2004 Kimball International, Inc.

NOTE: This instruction covers basic assembly of the extended corner return. For safety and ease of construction, the units are assembled upside down.

1

If the extended return has 2 recessed panels, place the worksurface and end panel face down on a smooth, solid surface. Screw threaded studs into each location indicated in Figure A. If the extended return has only 1 recessed panel, place the worksurface, end panel and full support panel face down on a smooth, solid surface. Screw threaded studs into each location indicated in Figure B.

Figure A

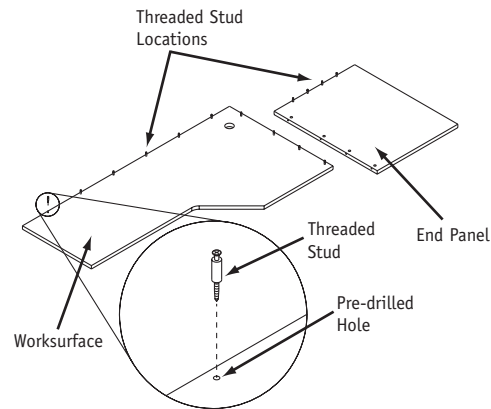

Figure B

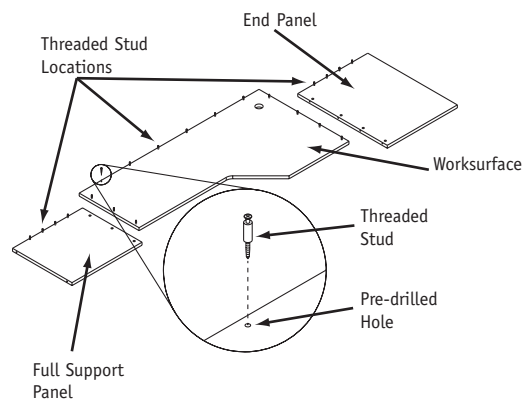
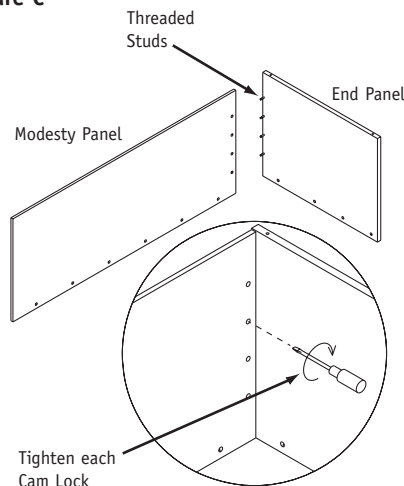

Figure C



2 Stand the end panel and modesty panel upside down and insert the exposed ends of the threaded studs on the end panel into the corresponding holes in the edge of the modesty panel. Make sure both panels are firmly seated against each other, then use a hand-held screwdriver to tighten the cam locks around each stud (Figure C). If the unit has the full support panel, stand it upside down and attach it to the modesty panel by inserting the exposed ends of the threaded studs on the support panel into the corresponding holes in the edge of the modesty panel. Make sure both panels are firmly seated against each other, then use the screwdriver to tighten the cam locks around each stud (Figure D).

Proper product installation, in accordance with these instructions, is the responsibility of the installing agent. If you have any questions concerning these instructions, please call National Customer Service.

**Extended Corner
Return
(with either 1 or 2
recessed panels)**

3

Carefully lift the modesty/end panel assembly and insert the exposed ends of the threaded studs in the worksurface into the corresponding holes in the edges of the assembled panels. Make sure the panels are firmly seated against the worksurface, then use a hand-held screwdriver to tighten the cam lock around each stud (Figure E). Or, carefully lift the modesty/end/full support panel assembly and insert the exposed ends of the threaded studs in the worksurface into the corresponding holes into the edges of the assembled panels. Make sure all panels are firmly seated against the worksurface, then use the screwdriver to tighten the cam locks around each stud (Figure F).

Figure D

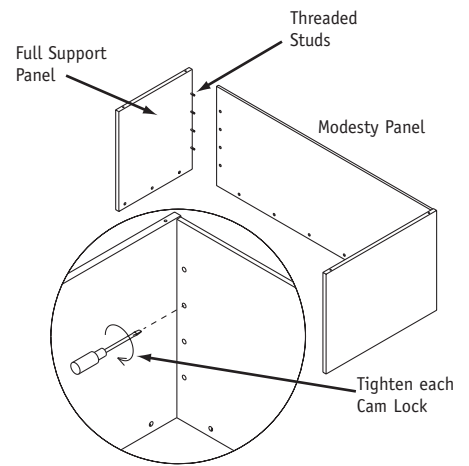

Figure E

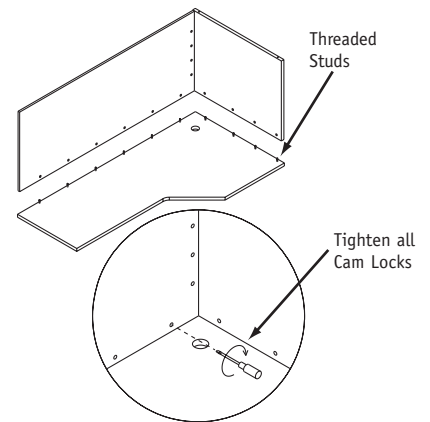
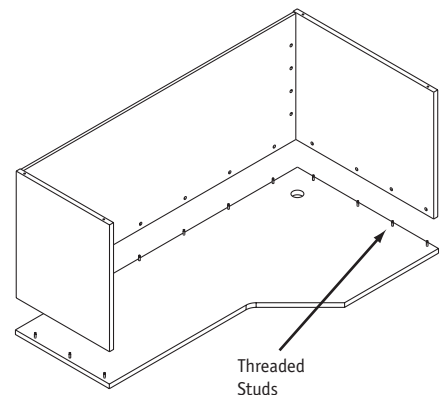

Figure F



**Extended Corner Return
(with either 1 or 2 recessed panels)**

4

Attach four (4) L-brackets to each small support panel at the approximate locations shown in Figure G using the provided 5/8" screws. Brackets must be inset 1/32" from edge of panel.

NOTE: The small support panel is shown upside down in Figure G.

Figure G

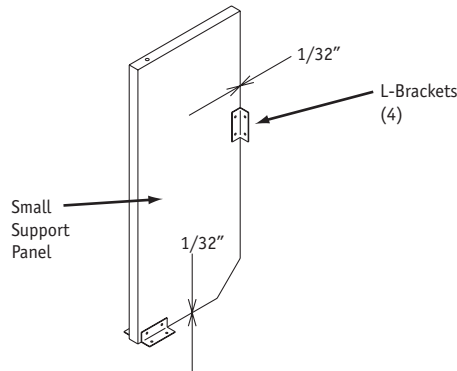

5

If the extended corner return has 2 recessed panels, attach them to the worksurface and panels at the approximate locations shown in Figure H using the provided 5/8" screws. Make sure the support panels are square and tight against all surfaces. If the extended return has only 1 recessed panel, attach it to the worksurface and end panel at the location shown in Figure I using the 5/8" screws provided. Make sure the support panel is square and tight against all surfaces.

Figure H

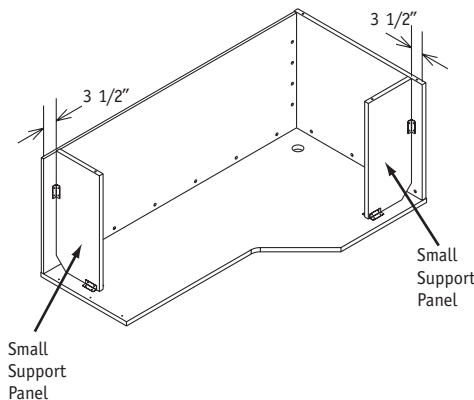
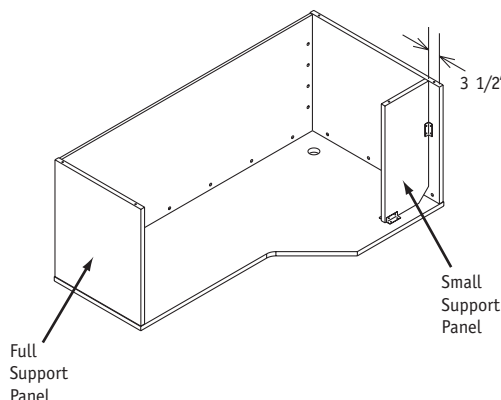

Figure I



Proper product installation, in accordance with these instructions, is the responsibility of the installing agent. If you have any questions concerning these instructions, please call National Customer Service.

Assembly Instructions

**Extended Corner Return
(with either 1 or 2 recessed panels)**

6 The extended corner return with 2 recessed panels must have a return mounting cleat attached at the location shown in Figure J. The mounting cleat has a “thick” and a “thin” side. Attach the “thick” side of the mounting cleat to the extended return modesty panel using four (4) of the provided mounting cleat screws. Make sure the “step” on the cleat is flush with the edge of the modesty panel as shown in the detail Figure J.

Figure J

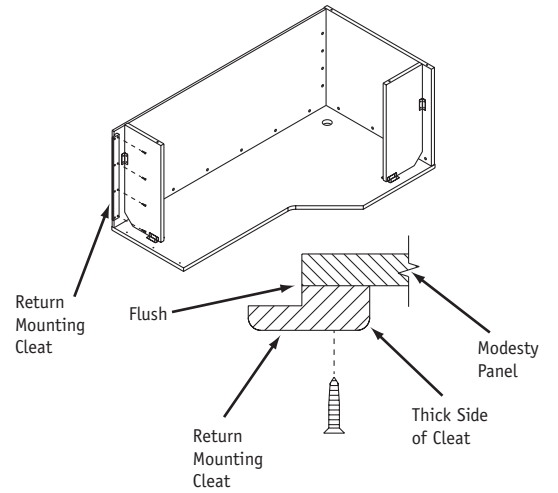

7 Make sure all screws and cam locks are firmly tightened. Carefully turn unit upright and move into desired location (Figure K).

Figure K

