

## Half Round Worksurface

**Note:** This instruction covers attaching the half round to end panels and to bridges or returns.

**1**

Place half round face down on a smooth, hard surface and attach cylinder leg (ordered separately) (Figure A).

**Figure A**

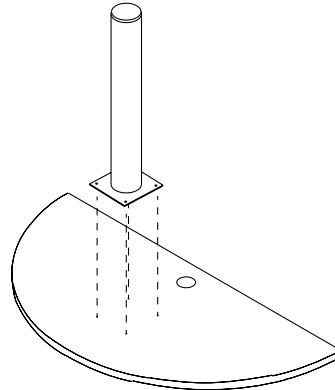

**2**

Place units with end panels next to each other and make sure ends are flush. To mount half round to end panels, attach (4) L-Brackets to end panels with screws provided. Tops of L-Brackets should be flush with bottom edge of worksurfaces (Figure B).

**Figure B**

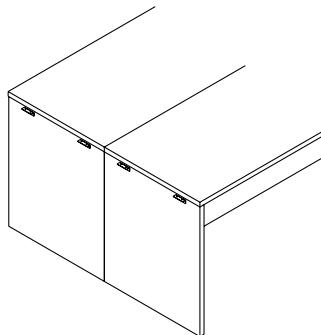

**3**

Turn half round upright and attach to L-Brackets using screws provided. Make sure half round is snug against side of worksurfaces and all edges are flush (Figure C).

**Figure C**

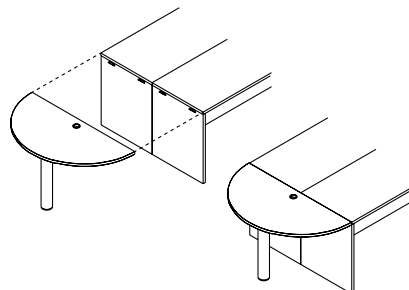

### Recommended Tools

- Screw Gun
- Level

### Package Contents

Contents	Qty.
• Half Round	1
• L-Brackets	4
• Screws	16

**NATIONAL**

Furniture with Personality™

Telephone 800.482.1717

Fax 812.482.8800

[www.furniture.kimball.com/nof](http://www.furniture.kimball.com/nof)

Form #NAIENVHR-01

#1491186

Printed in U.S.A

© 2001 Kimball International, Inc.

Proper product installation, in accordance with these instructions, is the responsibility of the installing agent. If you have any questions concerning these instructions, please call National Customer Care Teams.

## Half Round Worksurface

- 1** Follow Step 1 to attach cylinder leg to the half round worksurface (Figure A).

- 2** Place bridge/return units next to each other and make sure ends are flush. To mount half round to bridge/return units, attach (4) flat brackets (shipped with bridge/return) to underside of worksurface with screws provided overlapping the bracket by half (Figure D).

**Figure D**

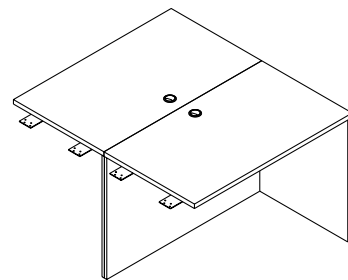

- 3** Attach half round to flat brackets using screws provided. Make sure half round is snug against side of worksurfaces and all edges are flush (Figure E).

**Figure E**

