

NOTE: This instruction covers basic attachment of a return to a reception center.

1

On the side the return will be connected to, attach two (2) flat brackets to the underside of the reception center worksurface using the provided 3/4" screws at the locations indicated (Figure A).

Figure A

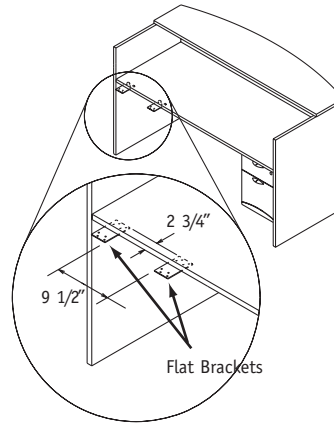

2

Move the return into position, with return worksurface resting on the flat brackets. Align worksurfaces and panels on both units so all surfaces are flush and have no gaps. Attach the underside of the return worksurface to the flat brackets using the provide 3/4" screws (Figure B).

Figure B

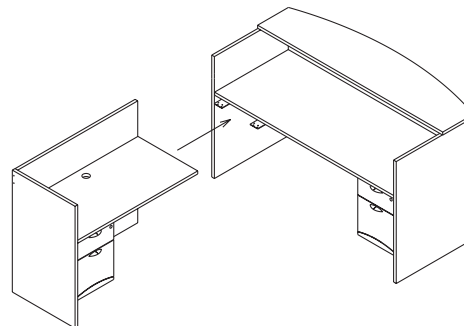

3

Re-check alignment of return modesty panel and reception center end panel to make sure all surfaces are flush with no gaps. Locate two (2) flat brackets at the positions indicated and attach the brackets to the return and reception center with the provided 3/4" screws (Figure C).

Figure C

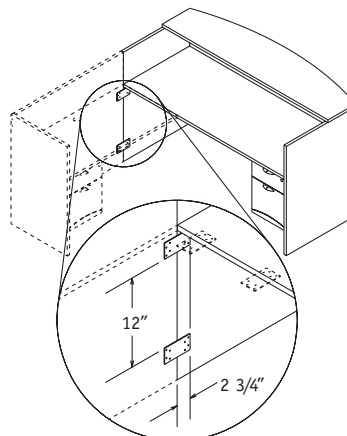

Assembly Instructions

Reception Station Return

Recommended Tools

- Power Screwdriver
- Phillips Head Bit

Package Contents	Qty.
• Reception Desk Return	per order
• Flat Brackets	4 per return
• 3/4" Wood Screws	8 per bracket

NATIONAL

Furniture with Personality®

Telephone 800.482.1717
 Fax 812.482.8800
 www.nationalonline.com

Form #NAIEWRS
 Part #1583415

Printed in U.S.A
 © 2004 Kimball International, Inc.

Proper product installation, in accordance with these instructions, is the responsibility of the installing agent. If you have any questions concerning these instructions, please call National Customer Service.