

Shell Base Desk

Note: For ease of construction, assemble the end and modesty panels upside down.

1 Turn worksurface face down on a smooth, hard surface. Take care not to mar the surface. Screw threaded studs into the pre-drilled holes (Figure A).

Figure A

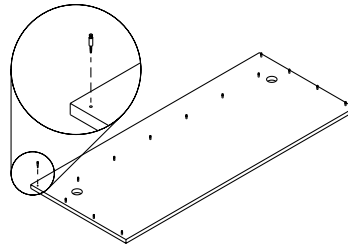

2 Turn end panels face down on a smooth, hard surface. Screw threaded studs into pre-drilled holes (Figure B).

Figure B

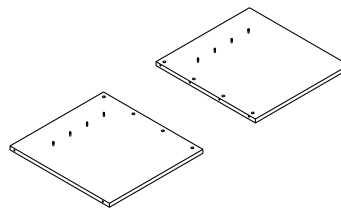

3 Stand one end panel and the modesty panel upright and insert the exposed end of the threaded studs on the end panel into the corresponding holes in the edge of the modesty panel. Use the screw driver to tighten the cam locks around each stud (Figure C).

Figure C

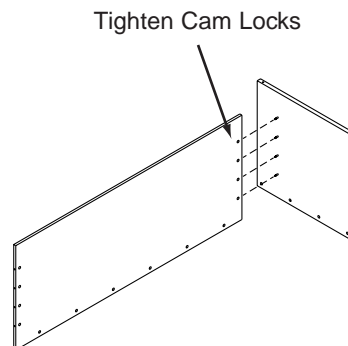

Recommended Tools

- Straight Screw Driver
- Screw Gun
- Level

Package Contents

	Qty.
• Top	1
• Modesty Panel	1
• End Panels	2
• Threaded Studs	(quantity varies with size of unit)

NATIONAL

Furniture with Personality™

Telephone 800.482.1717
 Fax 812.482.8800
www.furniture.kimball.com/nof

Form #NAIENVSD-01
 #1468042

Printed in U.S.A
 © 2001 Kimball International, Inc.

Proper product installation, in accordance with these instructions, is the responsibility of the installing agent. If you have any questions concerning these instructions, please call National Customer Care Teams.

Shell Base Desk

- 4** Assemble the other end panel to the back panel. Tighten all cam locks. Insert all leg levelers (Figure D).

Figure D

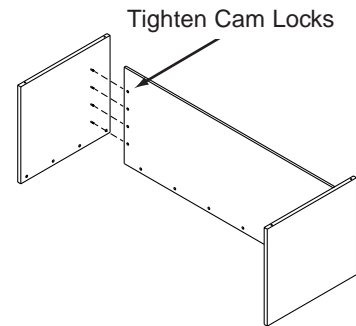

- 5** Lift the end panel/modesty panel assembly and attach it to the top worksurface by inserting the exposed ends of the threaded studs into the corresponding holes in the edges of the panels. Tighten all cam locks (Figure E).

Figure E

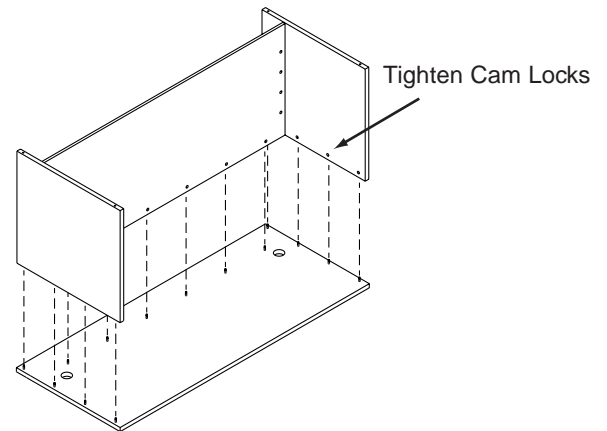

- 6** Turn shell upright and level unit (Figure F).

Figure F

