

1 To securely attach a Storage Unit to a Worksurface, place a strip of Double Sided Tape along the bottom edge of each end panel as shown. Do NOT remove the film backer to expose the adhesive (Figure A).

Figure A

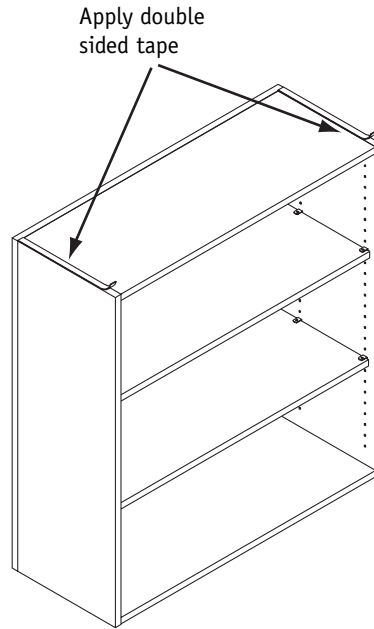

2 Position the Storage Unit on top of the Worksurface and mark it's location. Remove the film backers from the Double Sided Tape and adhere the Unit to the Worksurface. The Worksurface MUST be clean, dry and free of any dirt or film to assure adequate adhesion (Figure B).

Figure B

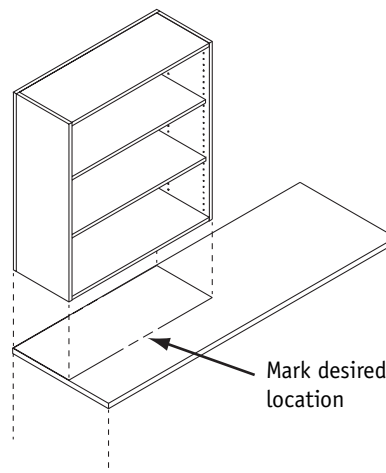

CAUTION: The Tape is a very strong adhesive and bonds instantly to any surface it is applied to.

Assembly Instructions

Above Surface Storage

Recommended Tools

- (none)

Package Contents

- | | Qty. |
|---------------------|-----------|
| • Double Sided Tape | per order |

NATIONAL

Furniture with Personality™

Telephone 800.482.1717
 Fax 812.482.8800
www.nationalonline.com

Form #NAIWAS2-99
 Part #1399224

Printed in U.S.A.
 © 2001 Kimball International, Inc.

Proper product installation, in accordance with these instructions, is the responsibility of the installing agent. If you have any questions concerning these instructions, please call National Customer Service.