

Leveling

Recommended Tools

- Level
- 7/32" nut driver

Note: All floor units MUST be leveled as described below for appearance and proper function of doors and drawers.

1

Desk, Credenza, Return, Lateral File, Drawer Storage:

Remove all drawers as required for access to leveling glide adjustment holes.

Note: To remove drawers, refer to the Pedestal Drawer Removal or Lateral File Drawer Removal Assembly Instruction sheet.

Turn the glides fully "in" (counterclockwise) prior to leveling. Level the unit from front-to-back by first extending the glides on the "outside" corners (turn clockwise); level the unit from side-to-side. Check adjustments by placing the level in the four (4) positions shown. Adjust inside glides (if applicable) to help support the desk/credenza (Figure A).

Figure A

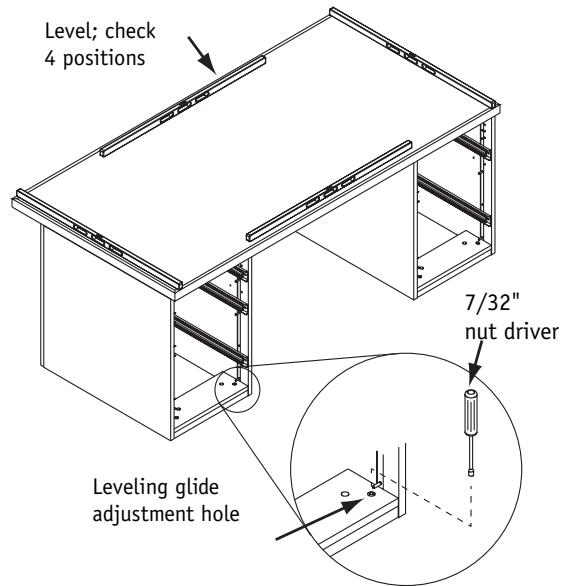

2

Bookcase, Cabinet Storage:

Locate and remove the four (4) hole plugs in the bottom panel to access the leveling glide adjustment holes. Turn the glides fully "in" (counterclockwise) prior to leveling. Level the unit from front-to-back by extending the glides (turn clockwise). Level the unit from side-to-side. Check adjustments by placing the level in the four (4) positions shown. Replace the hole plugs (Figure B).

Figure B

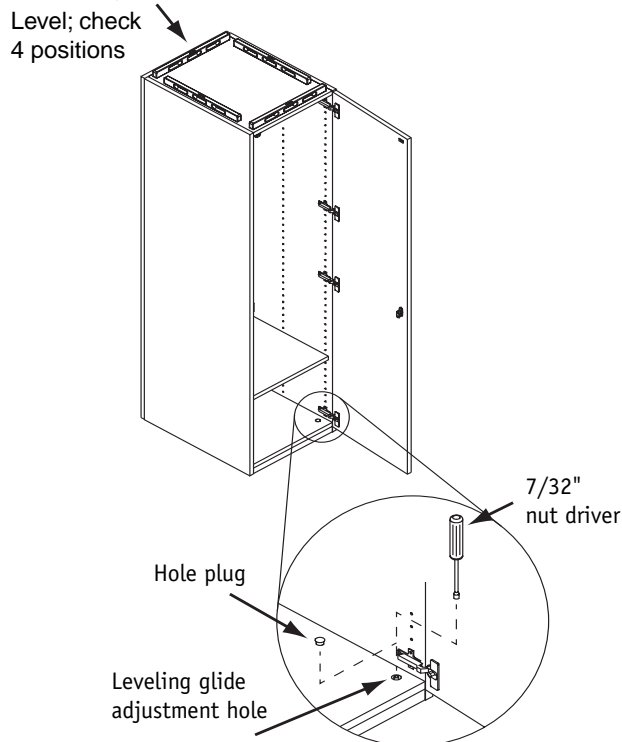

NATIONAL
Furniture with Personality™

Telephone 800.482.1717
Fax 812.482.8800
www.nationalonline.com

Form #NAIWLE-99
Part #1399193

Printed in U.S.A.
© 2001 Kimball International, Inc.

Proper product installation, in accordance with these instructions, is the responsibility of the installing agent. If you have any questions concerning these instructions, please call National Customer Service.

Leveling

3

CRT Corner, End Panel, Support Panel:

Locate all the glides on the bottom edges of the panels and turn fully "in" (counterclockwise). Extend each glide as required (turn clockwise) to level unit or Panel. Check adjustments by placing the level in the four (4) positions shown (Figure C).

Figure C

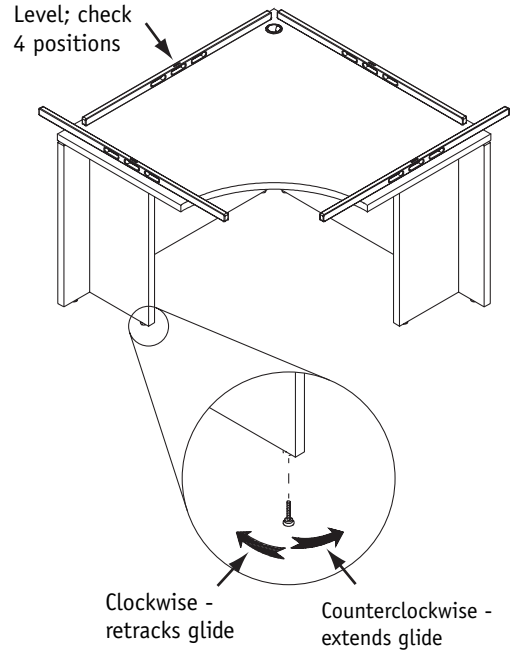

Proper product installation, in accordance with these instructions, is the responsibility of the installing agent. If you have any questions concerning these instructions, please call National Customer Service.