

Assembly Instruction

Casegoods

Florish Bullet Unit without Modesty Panel

Note: It is recommended that two or more people be used in the assembly of this unit.

Note: This instruction explains basic assembly of a bullet/keyhole unit with modesty panel.

1

Place the top worksurface face down on a smooth, hard surface. Take care to not mar the surface. Position cylinder leg mounting plate over the pre-bored holes in the worksurface. Attach cylinder leg using the four (4) #10 x 1" panhead screws provided (Figure A).

Figure A

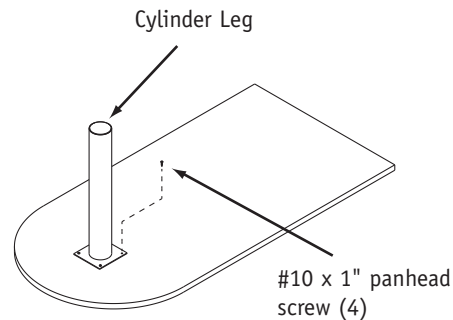

2

Position end panel 1/4" to the back edge of the top worksurface and center along its depth.

Note: Make sure the side of the end panel with the top groove faces to the OUTSIDE of the unit. Attach panel using four (4) L-brackets and 16 #8 x 5/8" panhead screws provided in the approximate locations shown (Figure B).

Figure B

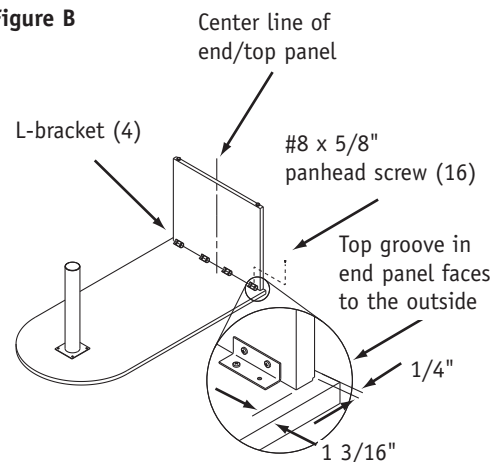

3

Attach Four (4) L-brackets to support panel, using eight (8) #8 x 5/8" panhead screws at locations shown in (Figure C).

Figure C

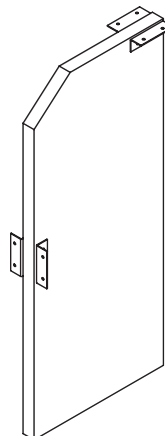

Recommended Tools

- Tape Measure
- Power Drill
- Phillips Screw Bit
- Square
- Level

Package Contents Qty.

BULLET UNIT	
• Top Worksurface	1
• End Panel	1
• Modesty Panel	1
• Cylinder Leg Bracket	1
• T-Bracket	1
• L-Brackets	8
• Adjustable Glide	2
• #8 x 5/8" Panhead Screws	32

CYLINDER LEG

• Cylinder Leg	1
• Adjustable Glide	1
• #10 x 1" Panhead Screws	4

NATIONAL Furniture with Personality

Telephone 800.482.1717
Fax 812.482.8800
www.nationalofficefurniture.com

Part# 2106953
Rev,

Printed in U.S.A
© 2009 Kimball International, Inc.

Proper product installation, in accordance with these instructions, is the responsibility of the installing agent. If you have any questions concerning these instructions, please call National Customer Service.

Assembly Instructions

Casegoods

Flourish
Bullet without
Modesty Panel

4

Attach the Support panel to the end panel using remaining #8 x 5/8" panhead screws. Make sure support panel is in the center of the End panel (Figure D).

Figure D

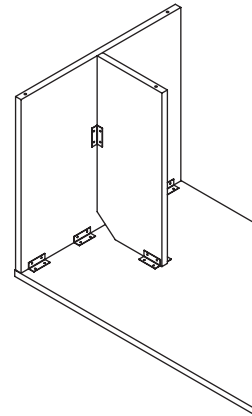

5

Square support panel and attach T-bracket to end panel and support panel using Five (5) #8 x 1 1/2" flat head screws (Figure E).

Figure E

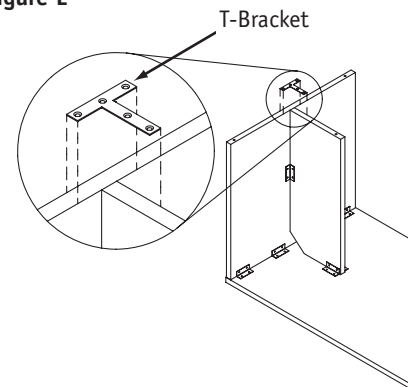

6

Carefully turn assembled unit upright and level by extending the two (2) adjustable glides in the end panel and one (1) 4" glide on the cylinder leg (Figure F).

Figure F

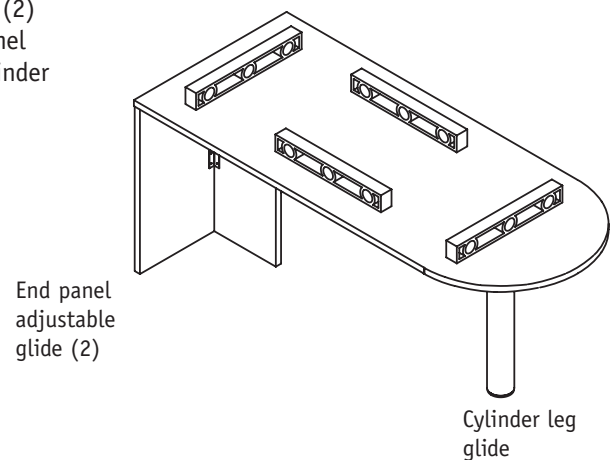

Proper product installation, in accordance with these instructions, is the responsibility of the installing agent. If you have any questions concerning these instructions, please call National Customer Service.