

Assembly Instructions

1

Place the long side panel face down on a smooth, hard surface. Take care to not mar the face. Attach three (3) L-brackets to the panel using the #8 x 5/8" panhead screws in the pre-drilled holes in the panel. The tops of the L-brackets must be flush with the edge of the panel (Figure A.)

Figure A

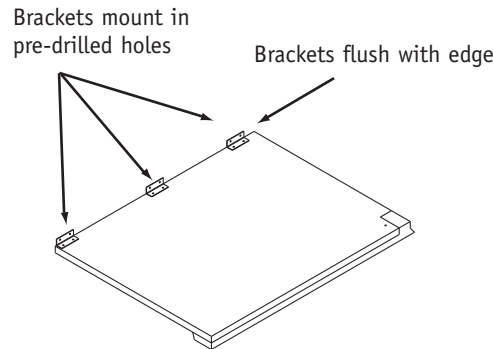

2

Place the short side panel face down on a smooth, hard surface. Take care to not mar the face. Attach four (4) L-brackets to the panel using the #8 x 5/8" panhead screws in the pre-drilled holes in the panel. The tops of the L-brackets must be flush with the edges of the panel. Attach the single leveling block to the panel using two (2) #8 x 1 3/4" panhead screws in the pre-drilled holes in the panel. The edge of the leveling block must be flush with the edge of the panel (Figure B).

Figure B

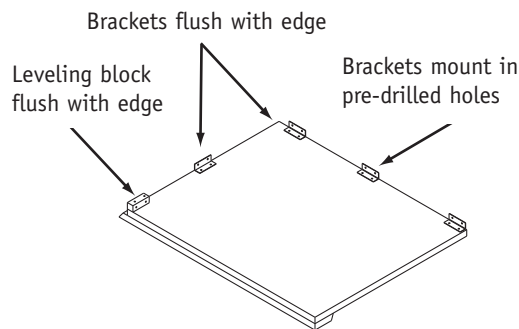

3

Attach four (4) L-brackets (2 on each side) to each support panel using the #8 x 5/8" panhead screws in the pre-drilled holes in each panel. The tops of the L-brackets must be flush with the edges of the panels.

Figure C

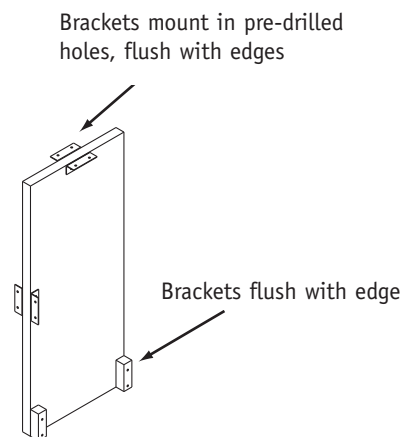

Note: Support panels have leveling blocks factory-installed (Figure C).

4

Place CRT top upside down on a smooth, hard surface. Take care to not mar the worksurface (Figure D).

Figure D

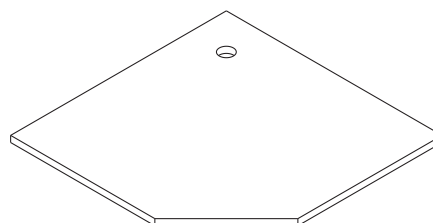

Casegoods

Roosevelt CRT

Recommended Tools

- Phillips Screwdriver

Package Contents

	Qty.
• CRT Top	1
• Long Side Panel	1
• Short Side Panel	1
• Support Panel w/leveling Blocks	2
• Leveling Block (unattached)	1
• L-Brackets	15
• #8 x 5/8" Panhead Screws	60
• #8 x 1 3/4" Panhead Screws	4

NATIONAL™

Telephone 800.482.1717
 Fax 812.482.8800
www.nationalofficefurniture.com

Part# 1493371
 Rev

Printed in U.S.A
 © 2009 Kimball International, Inc.

Proper product installation, in accordance with these instructions, is the responsibility of the installing agent. If you have any questions concerning these instructions, please call National Customer Service.

Assembly Instructions

Casegoods

Roosevelt
CRT

- 5** Attach L-brackets on the long and short side panels to the CRT top using the #8 x 5/8" panhead screws in the pre-drilled holes in the top. Attach the L-bracket in the middle of the short side panel to the long side panel using the #8 x 5/8" panhead screws in the pre-drilled holes in the long side panel.

Note: When side panels are mounted, they are inset 1 1/2" from the long sides of the top and flush with the two shorter sides of the top (Figure E).

Figure E

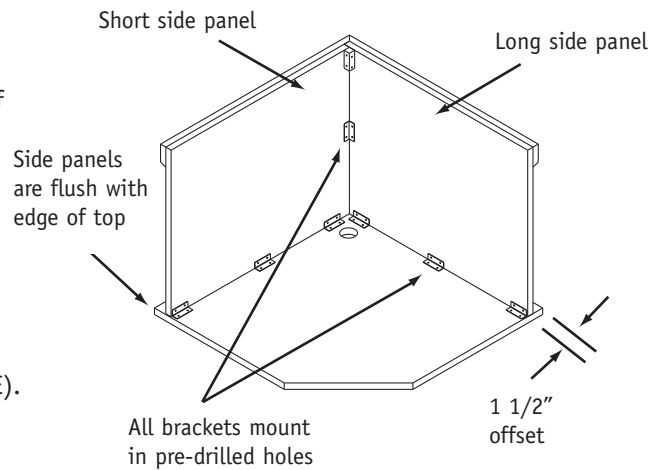

- 6** Attach L-brackets on support panels to the top and to the side panels using the #8 x 5/8" panhead screws in the pre-drilled holes. Make sure leveling blocks on support panels are towards the inside of the assembly. Attach the single leveling block to the long side panel using two (2) #8 x 1 3/4" panhead screws in the pre-drilled holes in the panel.

Note: When support panels are mounted, they are inset 3 1/2" from the edges of the top and side panels (Figure F).

Figure F

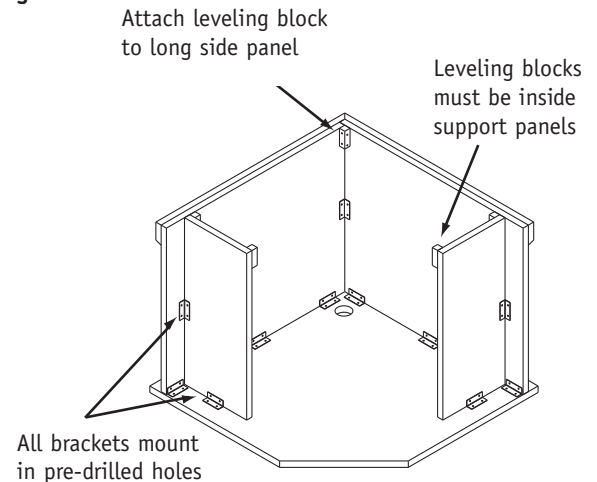

- 7** Tighten all screws securely. Carefully turn unit upright (Figure G).

Figure G

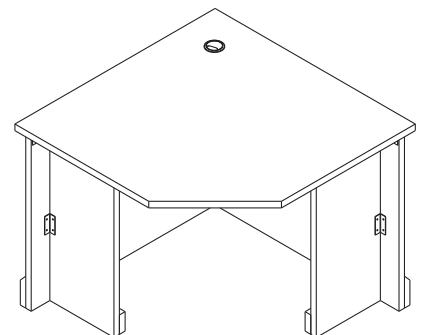

Proper product installation, in accordance with these instructions, is the responsibility of the installing agent. If you have any questions concerning these instructions, please call National Customer Service.