

Assembly Instructions

Note: This instruction explains installation of a task return to a desk. It is recommended that more than one person be used to assemble this unit. It is also recommended that the desk be in its intended location prior to attachment of the return.

1

Remove plastic film backer from one side of the adhesive tape. Adhere tape to the return's modesty panel edge, covering the dowel hole (Figure A).

Figure A

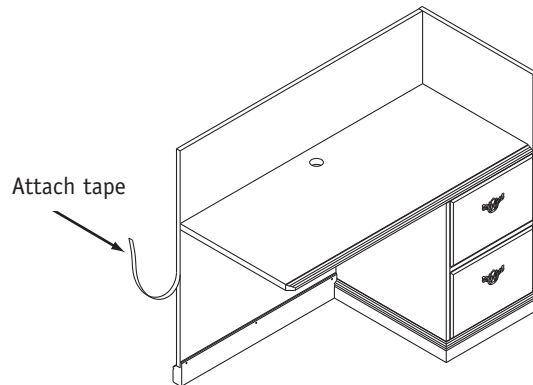

2

Cut tape away from dowel hole and insert dowel (Figure B).

Figure B

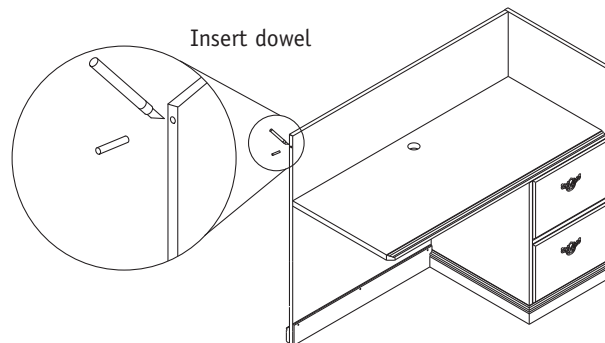

Cut tape from
dowel opening

3

Attach two (2) mounting brackets to underside of desk top, centering the brackets with the edge of the top. Use four (4) #10 x 5/8" panhead screws per bracket (Figure C).

Figure C

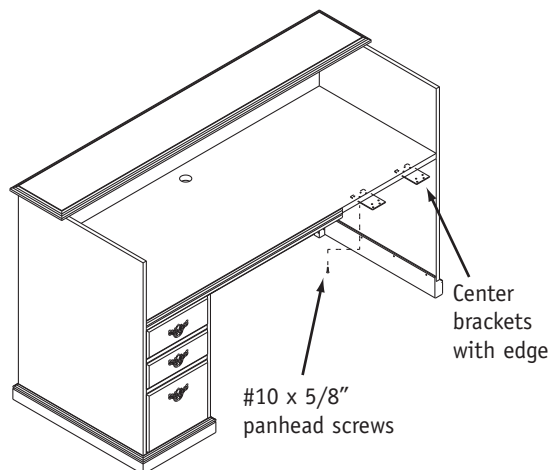

Casegoods

Roosevelt™ Reception Desk and Task Return

Recommended Tools

- Phillips Screwdriver
- Electric Drill
- Square

Package Contents

Qty.

- | | |
|---------------------------------|----|
| • Double Side Tape | 1 |
| • 5/16" x 1 3/16" Wooden Dowels | 1 |
| • Mounting Brackets | 4 |
| • #10 x 5/8" Panhead Screws | 32 |

NATIONAL™

Telephone 800.482.1717
Fax 812.482.8800
www.nationalofficefurniture.com

Part #2195770
Rev

Printed in U.S.A.
© 2009 Kimball International, Inc.

Proper product installation, in accordance with these instructions, is the responsibility of the installing agent. If you have any questions concerning these instructions, please call National Customer Service.

Assembly Instructions

Casegoods

Roosevelt™ Reception Desk and Task Return

- 4** Attach two (2) mounting brackets to inside of edge of desk and end panel, centering the brackets with the edge of the end panel. Use four (4) #10 x 5/8" panhead screws per bracket (Figure D).

Figure D

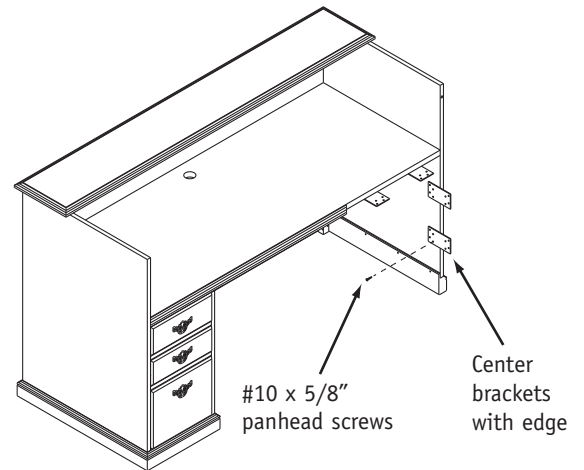

- 5** Remove remaining plastic film backer from adhesive tape on return. Align dowel in return with hole in desk. Push return towards desk, making sure dowel enter hole in desk. Make sure all worksurfaces and panels are flush, then press both units firmly together to eliminate any gaps (Figure E).

LEVELING:

Level both units before attaching the screws, reference Assembly Instruction #1399193

Figure E

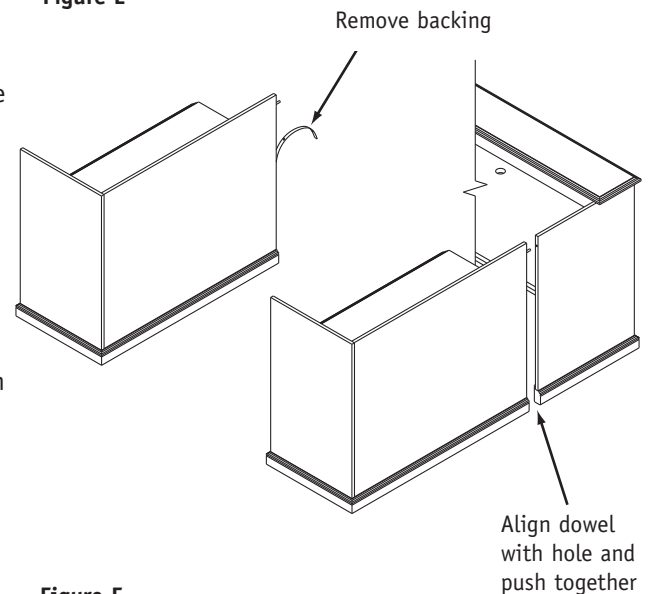

- 6** Attach all mounting brackets to the return using (16) #10 x 5/8" panhead screws. Make sure all gaps are eliminated and firmly tighten all screws (Figure F).

Figure F

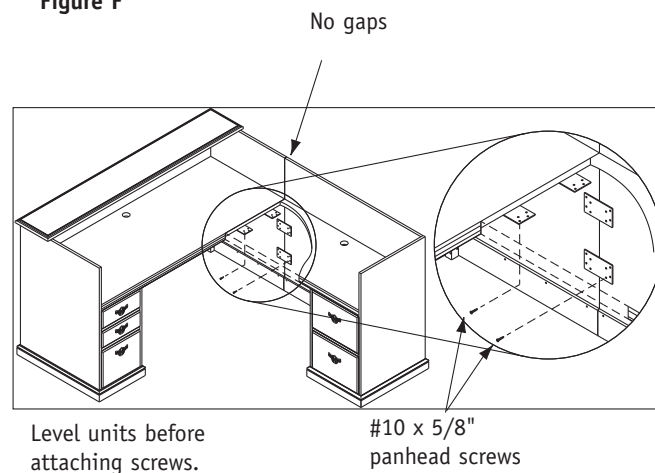

Proper product installation, in accordance with these instructions, is the responsibility of the installing agent. If you have any questions concerning these instructions, please call National Customer Service.