

ASSEMBLY INSTRUCTION

NOTE: This instruction shows the Roosevelt Magazine Table assembly as an example. This instruction can also be applied to end table and table desk assembly. It is recommended that more than one person be used to assemble and move the table.

1

Carefully uncarton and place worksurface face down on a smooth, clean, soft surface (Figure A).

Figure A

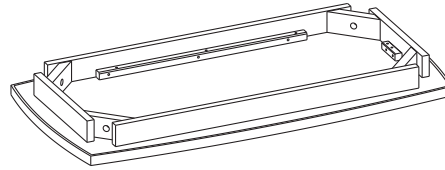

2

If previously installed, remove the nut, lock washer, and washer from the lag bolt on each leg (Figure B).

Figure B

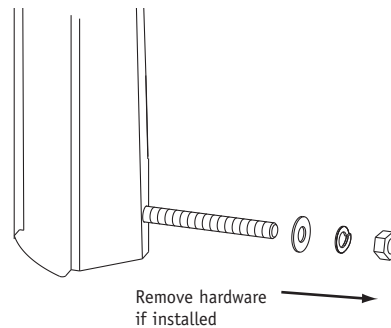

3

Insert the lag bolt on one leg through the hole in one corner block on the worksurface (Figure C).

Figure C

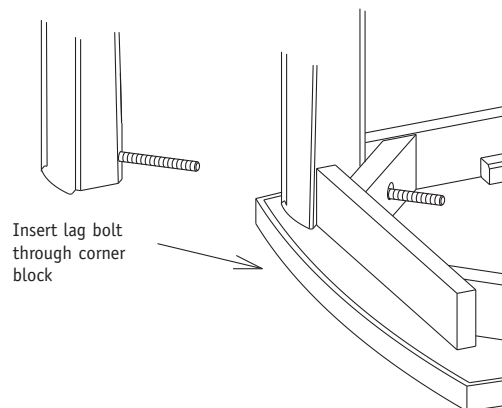

CASEGOODS

Roosevlet™ Tables

Recommended Tools

- Socket Wrench
- Adjustable Wrench

Package Contents	Qty.
• Table	1
• Table Legs with Washer, Lock Washer and Nut	4

NATIONAL™

Telephone 800.482.1717
Fax 812.482.8800
www.nationalonline.com

Part #2195766
Rev

Printed in U.S.A.
© 2009 Kimball International, Inc.

Proper product installation, in accordance with these instructions, is the responsibility of the installing agent. If you have any questions concerning these instructions, please call National Customer Service.

ASSEMBLY INSTRUCTION

Casegoods

Roosevelt™ Tables

- 4** Secure the leg to the table by installing the hardware in the following order: washer, lock washer, nut - to the inside of the corner block. Make sure the leg is perpendicular and flush to the apron rails. Tighten the nut firmly by using the socket wrench, but do not over-tighten (Figure D).

Figure D

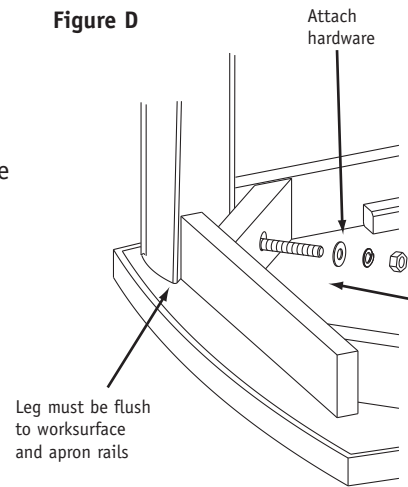

- 5** Refer to Steps 3 and 4 to install all remaining legs. After all legs are installed, carefully turn table to the upright user position (Figure E).

Figure E

