

Assembly Instructions

Wire Covers for Kite® and WaveWorks® Tables

Recommended Tools

none

Package Contents	Qty.
• Wire Cover	10 links

1

Make sure that the appropriate wire managers have been installed on your Kite and/or WaveWorks tables.

2

After routing the Intercoupler System through the wire managers, determine where you need wire covers (between wire managers to keep the cords from hanging down).

3

A standard wire cover consists of ten (10) links; however, all may not be required for your application. Before installing the wire cover, measure the distance between wire managers to determine if the removal or addition of links is necessary.

To remove links, rotate the links away from each other. Pull up on the upper locking tab while pressing down on the upper engaging tab and apply pressure until the links are disengaged (Figure A).

FIGURE A

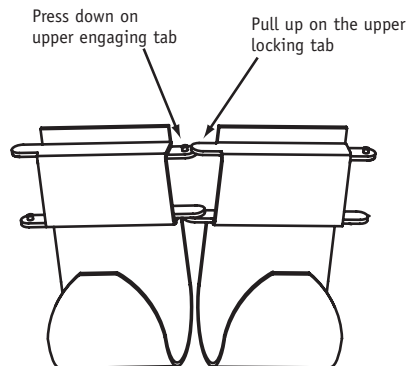

4

To install the wire cover assembly into the wire manager, align the upper tab and the lower edge of the lead link from the wire cover assembly into the upper and lower slots of the wire manager. Slide the link into the wire manager channel until it is completely inserted. Take the opposite link of the assembly and repeat the process to install into wire the other wire manager (Figure B).

FIGURE B

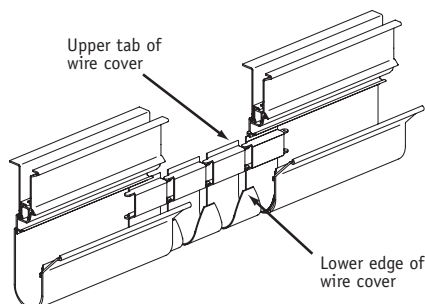

Proper product installation, in accordance with these instructions, is the responsibility of the installing agent. If you have any questions concerning these instructions, please call National Customer Service.

NATIONAL

Furniture with Personality®

Telephone 800.482.1717

Fax 812.482.8800

www.nationalonline.com

Part #115526

Printed in U.S.A.

© 2005 Kimball International, Inc.