

## 1

### Base Placement Chart

Table Length	A	B	Cylinders, Square, Queen Anne, Thick Panel	Thin panel, Curved, Metal Bases
72	18	NA		
84	18	NA		
96	18	NA		
120	24	60		
144	24	72		
168	24	64		
192	24	72 1/16		
216 (4Base)	24	28		
240 (4Base)	24	32		
216 (5Base)	24	66		
240 (5Base)	24	72		

#### Thin Panel Base

## 2

Attach L brackets to base using five (5) #10 x 5/8" panhead screws (Figure A).

Figure A

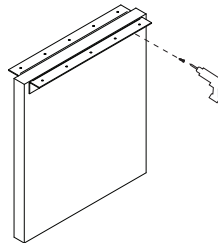
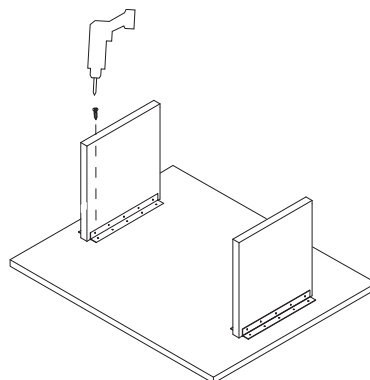

Figure B



## 3

Place the worksurfaces face down on a smooth, clean, dry surface. Per base placement chart position bases. Attach base with five (5) #8 x 5/8" panhead screws per bracket (Figure B).

### Conference and Training Solutions Thin Panel Base Veneer

#### Recommended Tools

- Tape Measure or Ruler
- Phillips Head Screwdriver

#### Package Contents Qty.

- 90 Deg L Brackets Per Order
- #10 x 3/4" Panhead Screws Per Order
- Mounting Brackets Per Order

# NATIONAL

Furniture with Personality®

Telephone 800.482.1717  
Fax 812.482.8800  
www.NationalOfficeFurniture.com

Part #2258947  
Rev,-

Printed in U.S.A  
© 2010 Kimball International, Inc.

## Assembly Instructions

### Thin Panel Base Veneer

- 4** Center the mounting brackets with the edge of the worksurfaces. Attach bracket to worksurface using #10 x 3/4" panhead screws, four (4) per bracket (Figure C).  
**NOTE:** Place brackets after bases have been applied per Base Placement Chart to ensure no interference.

Figure C

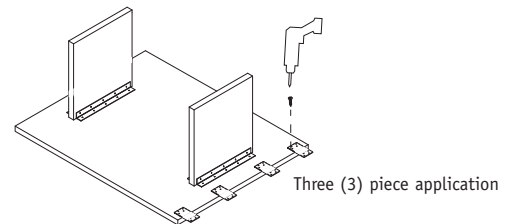
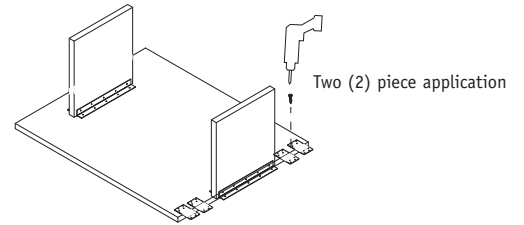

- 5** Locate Table in user position.  
**Two (2) Piece Worksurfaces Figure D**  
**Three (3) Piece Worksurfaces Figure E**  
Align and level worksurfaces to ensure there are no gaps or cracks. Attach mounting brackets using #10 x 3/4" panhead screws, four (4) per bracket.

Figure D

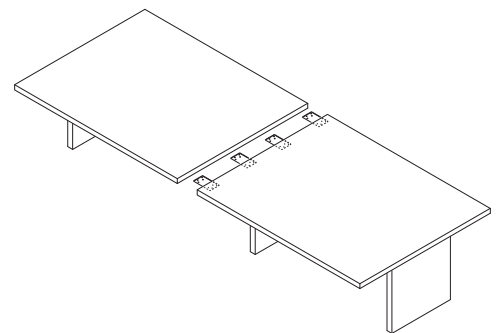

Figure E

