

ASSEMBLY INSTRUCTIONS

1

Place a strip of double sided tape along the bottom edge of each "L" support assembly. Do not remove backer to expose adhesive (Figure A).

Figure A

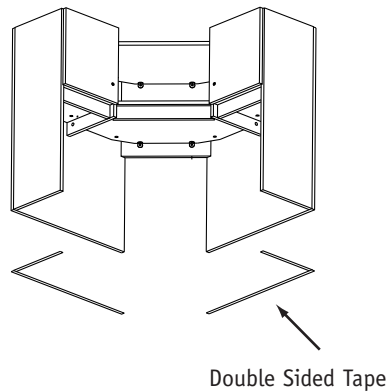

2

Position Closed Corner Hutch on top of the worksurface and mark it's location. Remove the film backers from the tape applied in step 1 and adhere unit to the worksurface. The worksurface must be clean, dry and free from dirt or film to assure adequate adhesion (Figure B).

Figure B

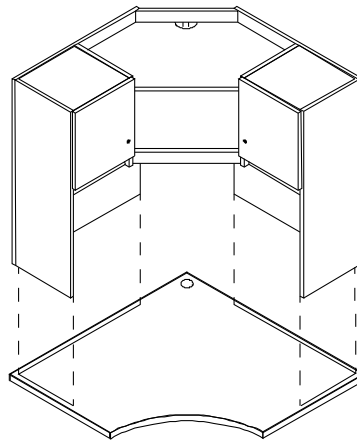

Note: The tape is a very strong adhesive and bonds instantly to the surface it is applied to.

WaveWorks® Casegoods Corner Hutch

Package Contents	Qty.
• Corner Hutch	1
• Double Sided Tape	

NATIONAL

Furniture with Personality®

Telephone 800.482.1717
Fax 812.482.8800
www.nationalonline.com

Part# 2048358

Printed in U.S.A.
© 2008 Kimball International, Inc.

Proper product installation, in accordance with these instructions, is the responsibility of the installing agent. If you have any questions concerning these instructions, please call National Customer Care Teams.