

## ASSEMBLY INSTRUCTIONS

1

Place the Left and Right "L" support back panels face down on a clean, solid surface. Insert three (3) minifix bolts into the prebored holes (Figure A).

Figure A

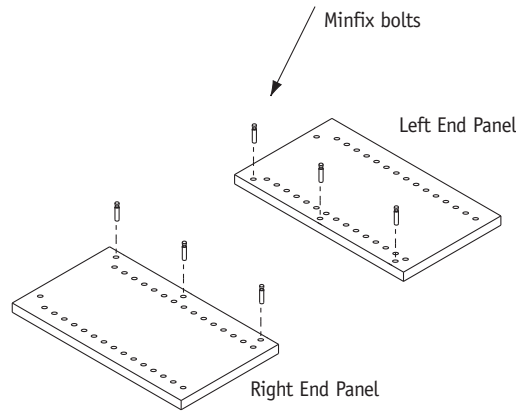

2

Insert the Minifix Housing into the hole in the side of each End Panel with the arrow facing toward the Bolt. Insert one (1) Double Head Minifix Bolt into the prebored hole on the top edge of each End Panel. Insert one (1) dowel into it's prebored hole. Tighten Housing approximately 1/2 turn until Bolt is secured (Figure B).

Figure B

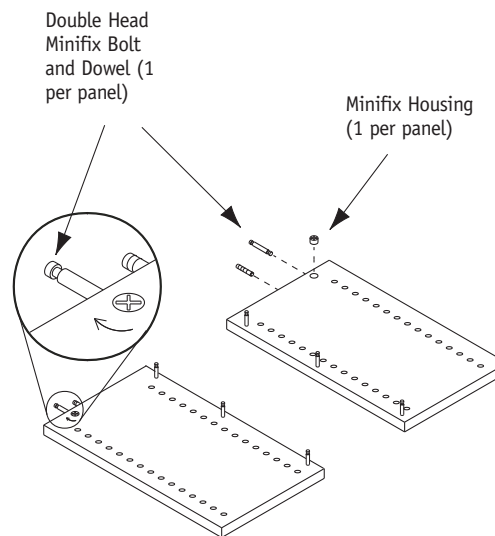

3

Locate the Left and Right "L" Support Back Panels. Align and insert the cam bolts into the cam lock holes. Turn the cam locks until tight.

Figure C

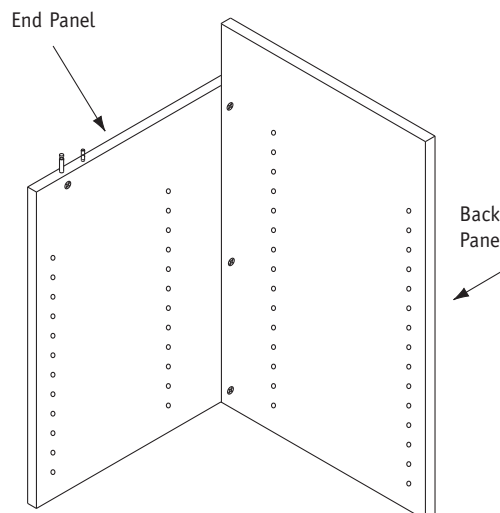

### WaveWorks® Highback Organizer Open Back

#### Recommended Tools

- Phillips Screwdriver
- Power drill
- Phillips Screw Bit

#### Package Contents Qty.

• "L" Support End Panel	2
• "R" Support End Panel	2
• Double Head Minifix Bolt	2
• Minifix TM Housing	8
• Highback Organizer Cabinet	1
• Double Sided Tape	5 ft.
• Shelf	4
• Shelf Bracket	16
• #8 x 1 1/4" Panhead Screw	4
• #6 x 5/8" Panhead Screw	16
• Single Head Minifix TM Post	6

## NATIONAL

Furniture with Personality®

Telephone 800.482.1717  
Fax 812.482.8800  
www.nationalonline.com

Part #2076628

Printed in U.S.A.  
© 2008 Kimball International, Inc.

Proper product installation, in accordance with these instructions, is the responsibility of the installing agent. If you have any questions concerning these instructions, please call National Customer Service.

WaveWorks®  
Highback Organizer  
Open Back

4

Place the Highback Organizer Cabinet upside down on a clean, solid surface or floor. Insert the Minifix Housing into the Cabinet End Panel. Position the Left and Right "L" Support Assemblies as shown so that the Double Head Minifix Bolt installed in Step 2 aligns with the Hole in the Cabinet End Panel. Tighten Minifix Housing until the "L" Support End Panel is fully seated. Attach the "L" Support Back Panel to the Cabinet Back Panel using two (2) #8 x 1 1/4" Pan Head Screws as shown (Figure D).

Figure D

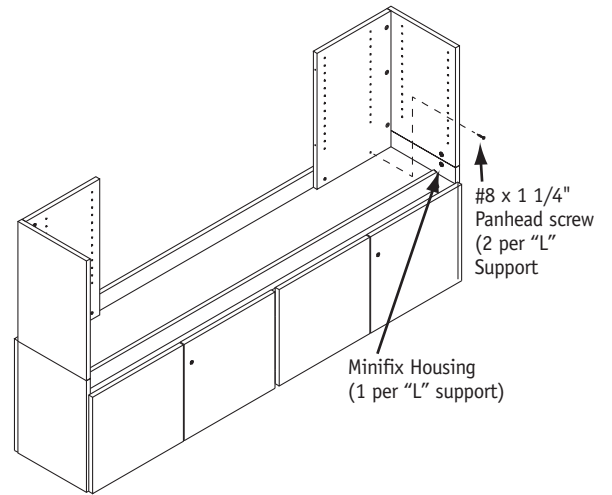

5

Place a strip of double sided tape along the bottom edge of each "L" Support End Panel. Do NOT remove film backer to expose adhesive. Place tape as close to the front without over hanging (Figure E).

Figure E

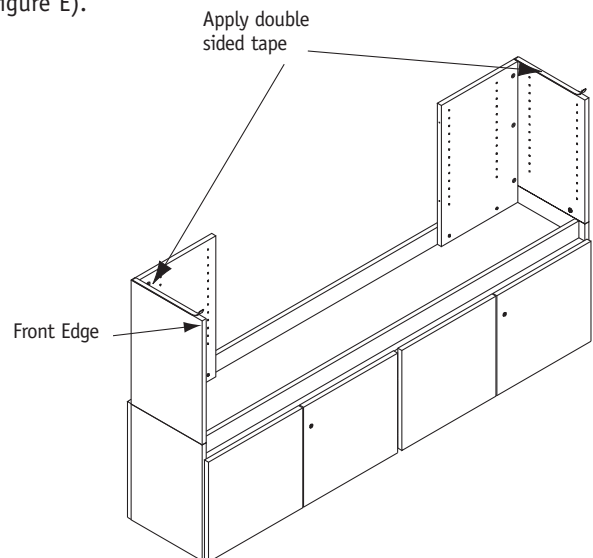

Proper product installation, in accordance with these instructions, is the responsibility of the installing agent. If you have any questions concerning these instructions, please call National Customer Service.

WaveWorks®  
Highback Organizer  
Open Back

6

Position the Highback Organizer on top of the worksurface and mark its location. Remove the film backers from the tape applied in Step 5 and adhere unit to the worksurface. The worksurface **MUST** be clean, dry and free from dirt or film to assure adequate adhesion (Figure F).

**Note:** The Tape is a very strong adhesive and bonds instantly to the surface it is applied to.

FIGURE F

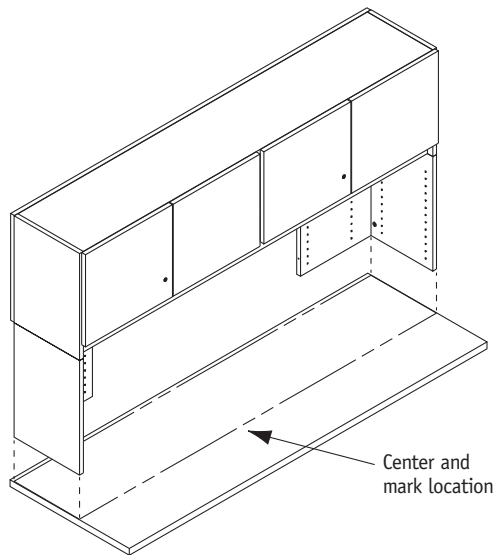

7

Position each shelf in the approximate desired location. Press four (4) Shelf Brackets per shelf into the nearest corresponding pre-bored holes as shown. Place Shelf on Shelf Brackets and attach to Brackets using four (4) #6 x 5/8" Pan Head Screws (Figure G).

FIGURE G

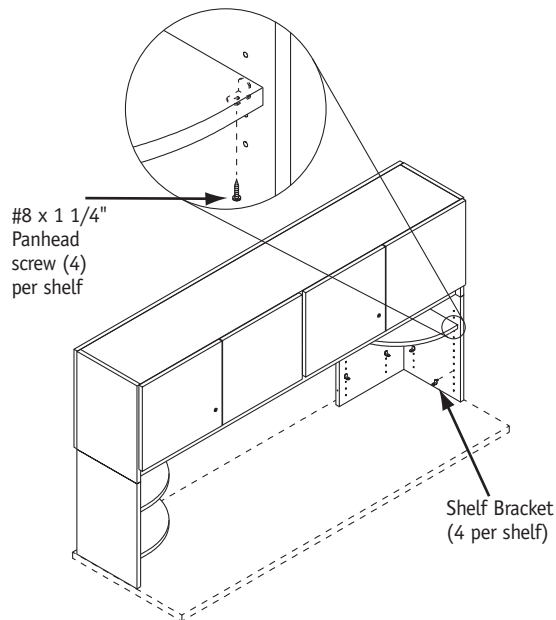

Proper product installation, in accordance with these instructions, is the responsibility of the installing agent. If you have any questions concerning these instructions, please call National Customer Service.