

ASSEMBLY INSTRUCTIONS

1

A Modular Worksurface can be used alone, or in combination with pedestals, modesty panels, end panels, or support panels to make any desired configuration (Figure A).

Note: Unsupported worksurface spans must NOT exceed 48" for 1 3/16" worksurfaces and 60" for 1 9/16" worksurfaces.

Figure A

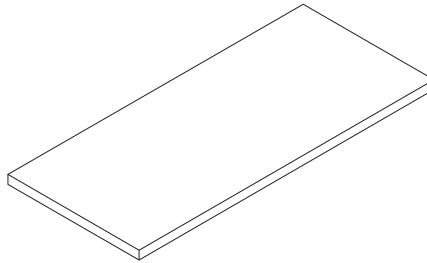

2

Position the main unit in the desired location. Level main unit. Install the flat brackets to the main unit using #10 x 1" Panhead screws provided (Figure B).

Note: To level, refer to the Leveling Assembly Instruction sheet, 2076621.

Figure B

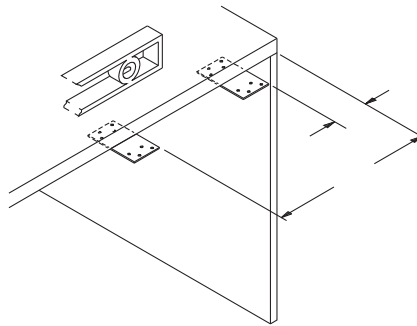

3

Align the worksurface to the main unit. Position the tops so the outer edge of the main unit and extension or filler worksurface are flush and pull tight against main unit. Fasten extension or filler worksurface to the flat brackets using #10 x 1" Panhead screws provided (Figure C).

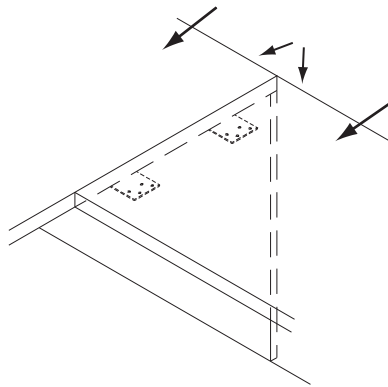

WaveWorks® Casegoods Modular Worksurface

Package Contents	Qty.
• Worksurface	1
• Flat Bracket	1
(extension)	2
(filler)	4
• #10 x 1" Panhead screw	
(extension)	16
(filler)	32

NATIONAL

Furniture with Personality®

Telephone 800.482.1717
Fax 812.482.8800
www.nationalonline.com

Part #2076615

Printed in U.S.A.
© 2008 Kimball International, Inc.

Proper product installation, in accordance with these instructions, is the responsibility of the installing agent. If you have any questions concerning these instructions, please call National Customer Care Teams.