

ASSEMBLY INSTRUCTIONS

Main Shell Set Up

1

Place units in their final position. Pre-bore the end panel with a 3/16" holes (Figure A).

Note: ADA unit uses only the bottom two (2) holes.

Figure A

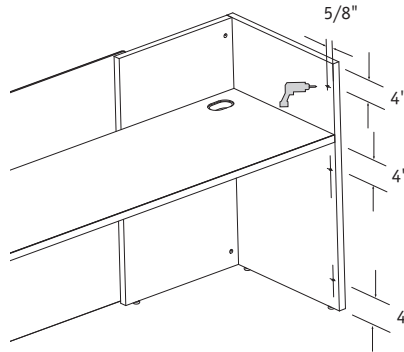

2

Attach mounting brackets the underside of the worksurface. Center the brackets with the edge of the worksurface. Attach brackets using four (4) #10 x 1" panhead screws per bracket (Figure B).

Figure B

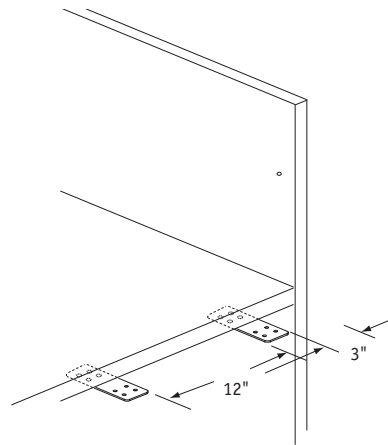

Bridge Set Up

3

Attach four (4) L brackets where the prebored are located with four (4) #8 x 5/8" panhead screws (Figure C).

Figure C

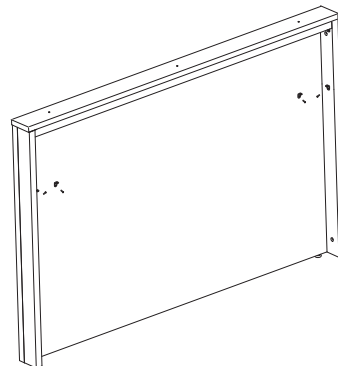

WaveWorks® Reception Desk Hookup

Recommended Tools

- Phillips Screwdriver
- Tape measure
- Drill
- 3/16" Drill Bit
- Allen Wrench

Package Contents Qty.

- #8 x 5/8" Panhead Screw Per Order
- #8 x 1" Panhead Screw Per Order
- #8 x 2 1/2" Panhead Screw Per Order
- #10 x 1" Panhead Screw Per Order
- 1 1/2" x 5/16" Set Screw Per Order
- Spacer Per Order
- Washer Per Order
- End Cap Per Order

NATIONAL

Furniture with Personality®

Telephone 800.482.1717
Fax 812.482.8800
www.nationalonline.com

Part #2048357

Printed in U.S.A
© 2008 Kimball International, Inc.

Proper product installation, in accordance with these instructions, is the responsibility of the installing agent. If you have any questions concerning these instructions, please call National Customer Service.

ASSEMBLY INSTRUCTIONS

WaveWorks® Reception Desk Hookup

4 Attach the worksurface to the modesty panel using the four (4) L brackets and four (4) #8 x 1" panhead screws. Attach two (2) L brackets to the modesty panel and worksurface with two (2) #8 x 5/8" panhead screws into the modesty and two (2) #8 x 1" panhead screws into the worksurface at the approximate locations shown (Figure E).

Figure E

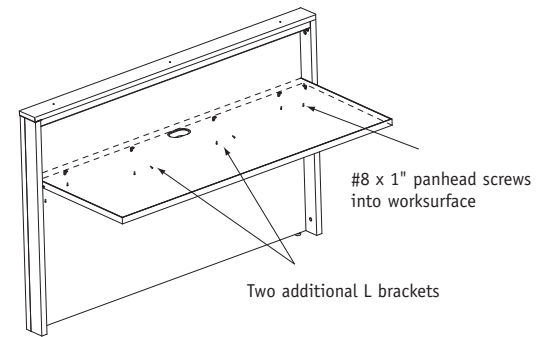

5 Align and **Level Units**, attach Units through the prebored holes with three (3) #8 x 2 1/2" panhead screws. Attach the flat brackets using four (4) #10 x 1" panhead screws per bracket (Figure F). Repeat process for the other side.

Figure F

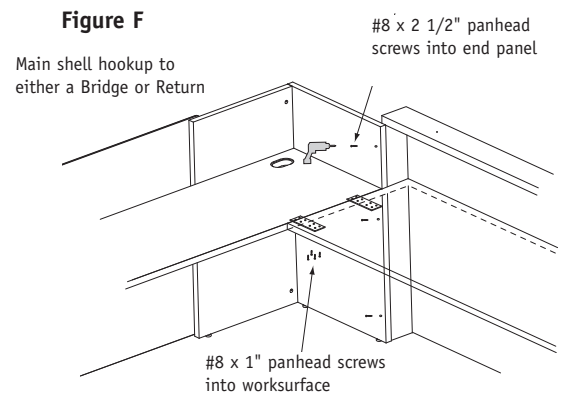

Note: ADA unit uses only the bottom two holes.

6 Remove the four (4) screws holding the top panel. Place glass worksurface face down on a non-marring surface. Attach the top panel to the glass worksurface into the three (3) stanchions with three (3) #5/16-18 x 1 1/2" panhead screws. Reposition top panel with glass back into unit, attach with the 4 screws (Figure G).

Figure G

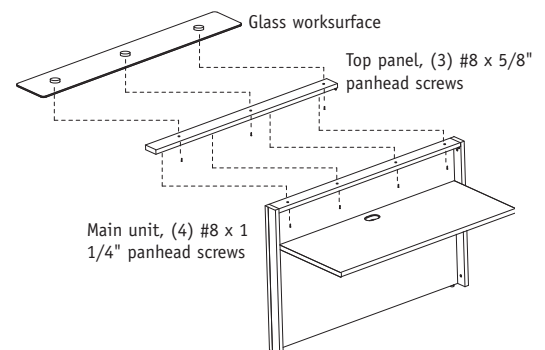

7 Screw spacer on to the set screw 1/2". Screw set screw and spacer into T-Nut that is in the modesty panel. Repeat process for all four (4). Place one (1) washer on each set screw. Place glass on to the four (4) set screw assemblies. While holding glass, place washer on to set screw next to the glass, hand tighten the end cap. Repeat process for all four (4).

Figure H

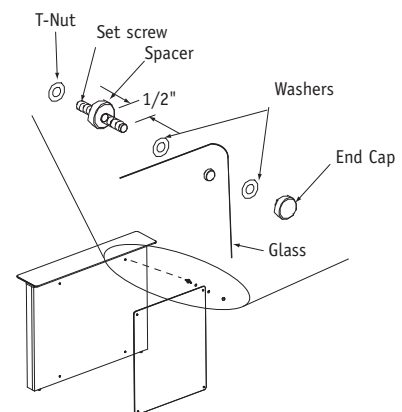

Proper product installation, in accordance with these instructions, is the responsibility of the installing agent. If you have any questions concerning these instructions, please call National Customer Service.