

ASSEMBLY INSTRUCTIONS

WaveWorks® Undersurface Support Rail

- 1** Place the worksurface down on a clean, dry level surface. Position the Undersurface Support Rail in the center of the worksurface with the two (2) side flanges seated on the underside of the worksurface. Attach the undersurface support rail using twelve (12) #10 x 1" panhead screws Figure A.

Figure A

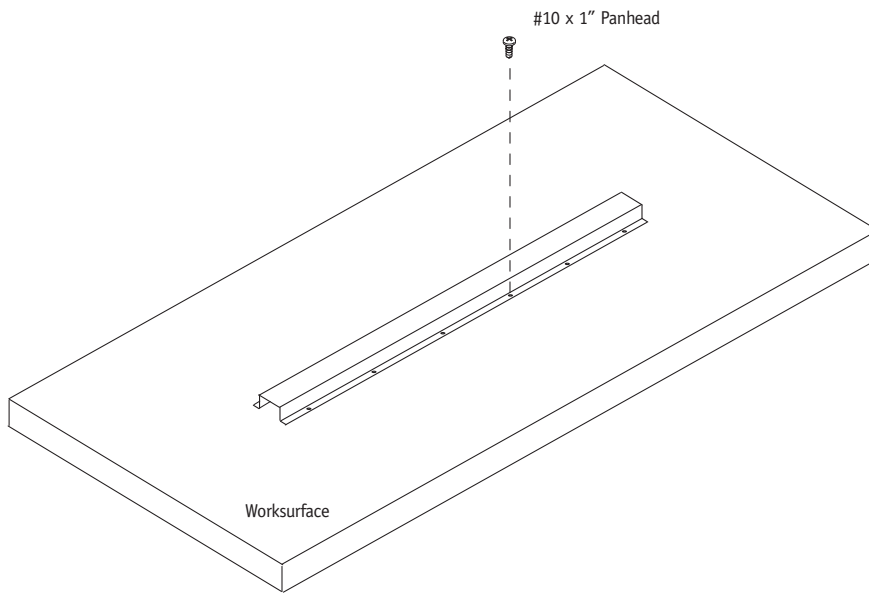

Recommended Tools

- Tape Measure
- #2 Phillips Head Bit
- Screw Gun

Package Contents	Qty.
• #10 x 1" Panhead Screws	12
• Support Rail	1

NATIONAL

Furniture with Personality®

Telephone 800.482.1717
Fax 812.482.8800
www.nationalonline.com

Part # 2076614

Printed in U.S.A.
© 2006 Kimball International, Inc.

Proper product installation, in accordance with these instructions, is the responsibility of the installing agent. If you have any questions concerning these instructions, please call National Customer Service.