

## Assembly Instructions

Casegoods

### Folding T-Leg for 48", 54" and 60" worksurfaces

#### Recommended Tools

- Power Screwdriver
- Phillips Screwdriver

Package Contents	Qty.
• Folding T-leg (short)	1
• Folding T-leg (long)	1
• #12 x 1" Panhead Screws	12
• Riser Rails	2
• Machine Screws	6

1

Place worksurface face down on a smooth, hard surface. Attach (2) two riser rails to the short folding leg with (6) six machine screws provided (Figure A).

Figure A

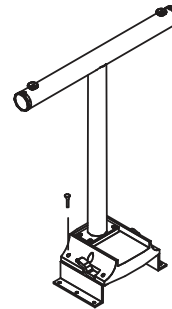

2

Check Figure G to determine proper placement of T-legs on underside of worksurface. Attach legs to worksurface using six (6) #12 x 1" Panhead screws provided (Figure B).

Figure B

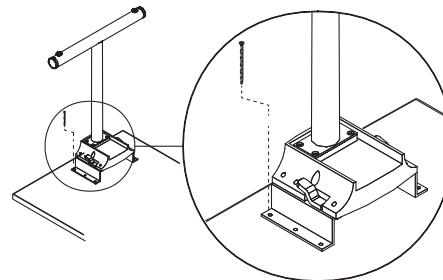

**NOTE:** Open end of folding T-leg bracket must face towards the center of the worksurface.

3

Refer to Figure G for measurements and attach second folding T-leg to worksurface using six (6) #12 x 1" Panhead screws (Figure C).

Figure C

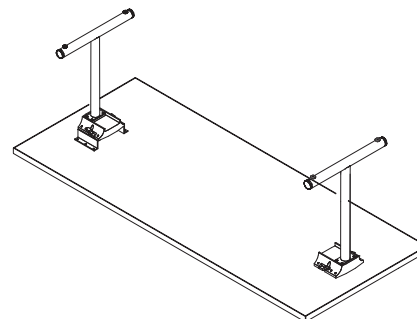

NATIONAL | Furniture with Personality™

Telephone 800.482.1717  
Fax 812.482.8800  
www.NationalOfficeFurniture.com

Part #1567858  
Rev,-

Printed in U.S.A  
© 2010 Kimball International, Inc.

Proper product installation, in accordance with these instructions, is the responsibility of the installing agent. If you have any questions concerning these instructions, please call National Customer Service 800.482.1717.

# Assembly Instructions

Casegoods

## Folding T-Leg for 48", 54" and 60" worksurfaces

**4** Carefully turn assembled table upright (Figure D).

Figure D

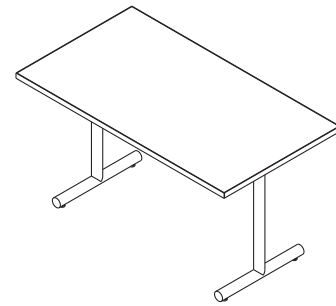

**5** To fold T-legs, turn table upside down on a smooth, hard surface.

Figure E

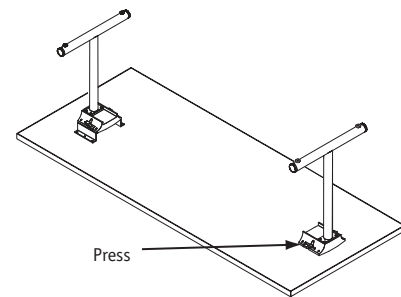

**NOTE:** Fold long T-leg first. Press tab on outside of T-leg bracket to unlock T-leg. Allow leg to rotate inward until it locks in the down position (Figure E).

**6** Repeat Step 5 to fold short T-leg. The spacers allows the short T-leg to fold flat over the long T-leg (Figure F).

Figure F

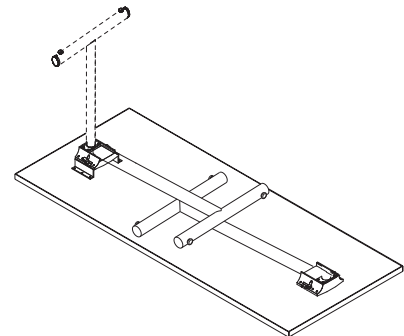
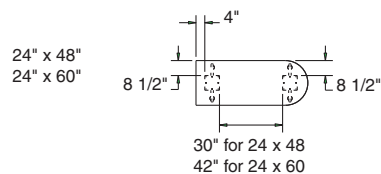
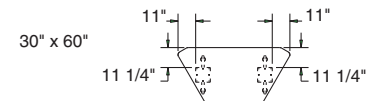
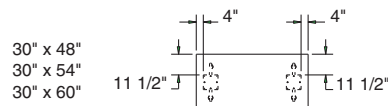
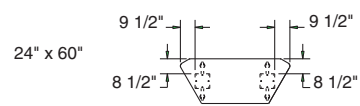
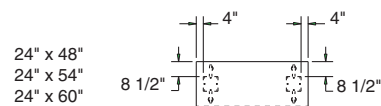

Figure G



Proper product installation, in accordance with these instructions, is the responsibility of the installing agent. If you have any questions concerning these instructions, please call National Customer Service 800.482.1717.