

## Assembly Instruction

- 1 Unpack the desk and set into position.

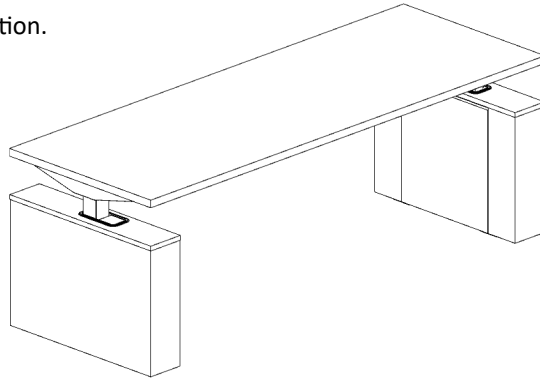

Figure A

- 2 Remove two flat brackets from the bottom of each shroud to access the interior as needed. Brackets can be discarded (Figure B) as they are only installed to protect during shipping.

**NOTE: Removable panel hangs from Z-clip brackets. Once flat brackets are removed care should be taken so that the panel does not disengage from Z-clip and damage the component.**

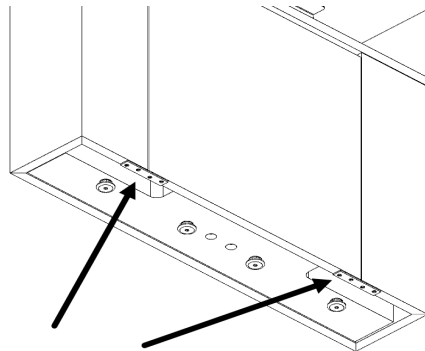

Figure B

- 3 Install glides (Qty. 4 per shroud) supplied in hardware kit to underside of each shroud (Figure C)

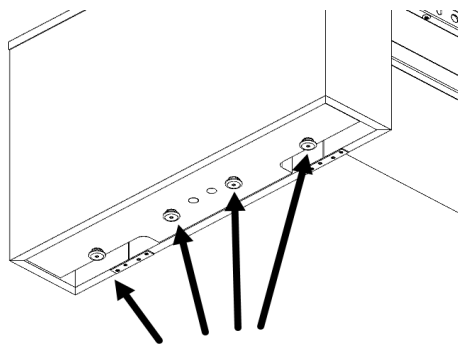

Figure C

### TESSERA HGT. ADJ. DESK

#### Tools Required

- Screw Driver w/ #2 Phillips Bit
- Level
- Cable ties

#### Hardware

- Glides x8

# NATIONAL

Furniture with Personality®

Telephone 800.482.1717  
Fax 812.482.8800  
[www.NationalOfficeFurniture.com](http://www.NationalOfficeFurniture.com)

3206401  
Rev. -

Proper product installation, in accordance with these instructions, is the responsibility of the installing agent. If you have any questions concerning these instructions, please call National Customer Service 800.482.1717.

## Assembly Instruction

- 4** Position desk in final location and level the unit using the glides (Figure D).

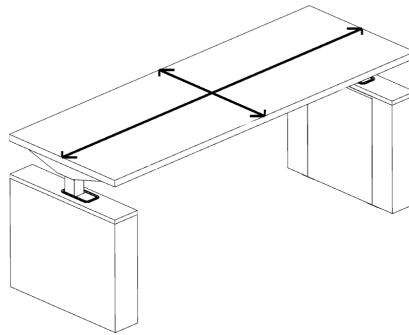

Figure D

- 5** The shroud's interior panels can be removed to access the wire manger by pulling up to clear the Z-clip then away to free the panel from the shroud (Figure E).

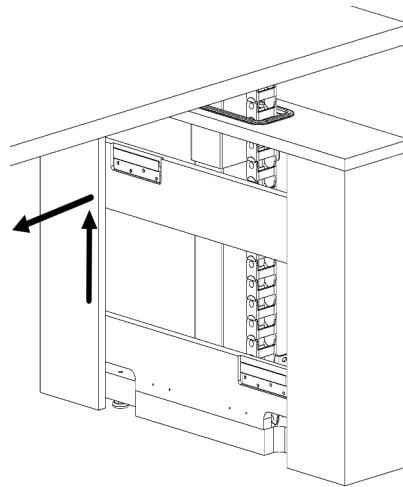

Figure E

- 6** The wire manager comes installed on the user's right side shroud. If this is the preferred location proceed to **Step 7**. If this isn't the preferred position see the **Wire Manager Relocation** section at the end of this instruction to relocate it to the left side shroud. After this relocation procedure is complete proceed to **Step 7**.
- 7** Run power and accessory lines through wire manager ensuring all leads run the full length of the wire manager.

**WARNING:** Lines running to worksurface **MUST** be routed through the full length of the wire manager to ensure enough lead length is available to support the mechanism's full range of motion.

- 8** Replace removable panel back onto the shroud Z-clip hangers.
- 9** Power up unit and review mechanism manual for recalibration and usage.

Proper product installation, in accordance with these instructions, is the responsibility of the installing agent. If you have any questions concerning these instructions, please call National Customer Service 800.482.1717.

## TESSERA HGT. ADJ. DESK

NATIONAL

Furniture with Personality™

Telephone 800.482.1717  
Fax 812.482.8800  
[www.NationalOfficeFurniture.com](http://www.NationalOfficeFurniture.com)

3206401  
Rev. -

## Assembly Instruction

TESSERA HGT. ADJ.  
DESK

# Wire Manager Relocation

- 1A** Ensure the height adjustable mechanism is unplugged before moving on.  
If not done so already remove the access panel on both shrouds. Remove all wires back through the wire manager so that its empty (Figure F).

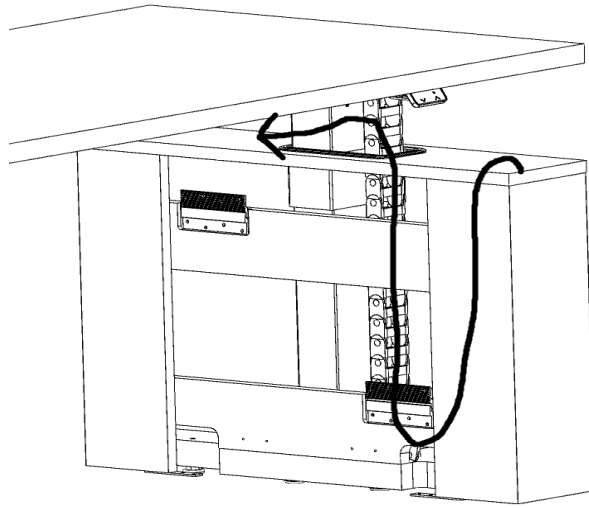

Figure F

- 2A** Remove four screws securing wire manager. There are two attached to the underside of the worksurface and two on the underside of the shroud top (Figure G).

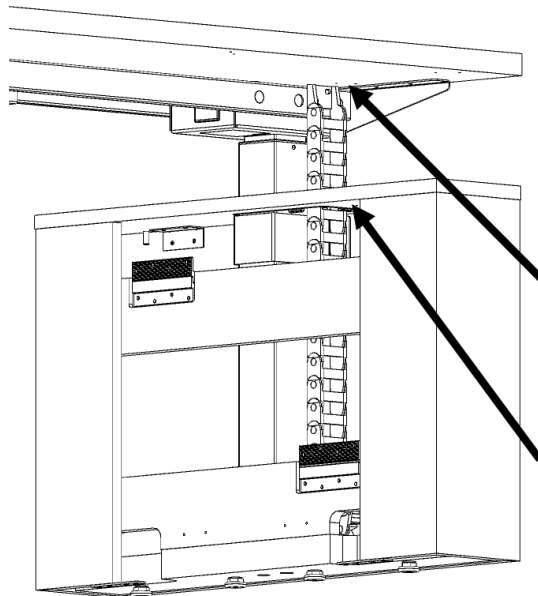

Figure G

**NATIONAL**

Furniture with Personality™

Telephone 800.482.1717  
Fax 812.482.8800  
[www.NationalOfficeFurniture.com](http://www.NationalOfficeFurniture.com)

3206401  
Rev. -

Proper product installation, in accordance with these instructions, is the responsibility of the installing agent. If you have any questions concerning these instructions, please call National Customer Service 800.482.1717.

## Assembly Instruction

**3A** On the opposite side shroud remove the grommet cap (Figure H) installed in the top of the shroud. This cap is retained by tabs on both sides of the cap (Figure I). Depress these tabs in and push out to remove cap from the grommet (Figure J). Re-install this cap on the shroud without the wire manager to close off the grommet hole.

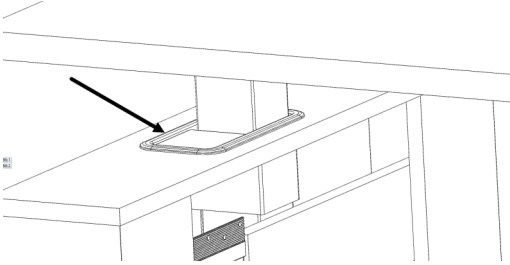

Figure H

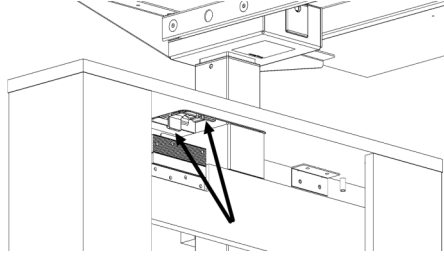

Figure I

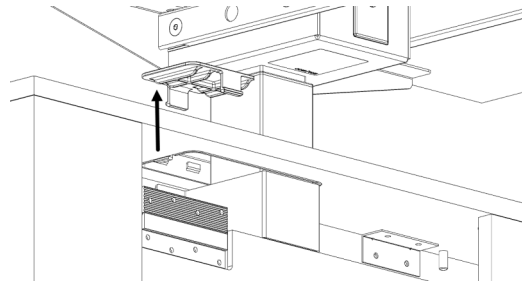

Figure J

**4A** Reusing the removed hardware install the wire manager in the new location in the same manner as it was installed originally (Figure K).

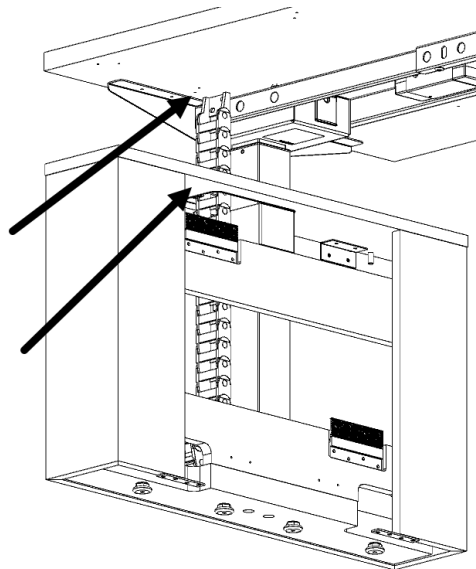

Figure K

**TESSERA HGT. ADJ.  
DESK**

**NATIONAL**

Furniture with Personality™

Telephone 800.482.1717  
Fax 812.482.8800  
[www.NationalOfficeFurniture.com](http://www.NationalOfficeFurniture.com)

3206401  
Rev. -

Proper product installation, in accordance with these instructions, is the responsibility of the installing agent. If you have any questions concerning these instructions, please call National Customer Service 800.482.1717.

## Assembly Instruction

### 5A (For L Unit Installation) Return to Tessera Return Install AI Step 9

#### (For Desk Unit Only Installation)

The control box and power supply will need to be shifted to the opposite side to allow for the power supply cord to run down the repositioned wire manager. Remove fasteners, re-position, and reinstall power supply bracket, control box, and handset to underside of worksurface reusing original fasteners. See right mount (Figure L) and left mount (Figure M) layouts below for reference. Positions are approximate.

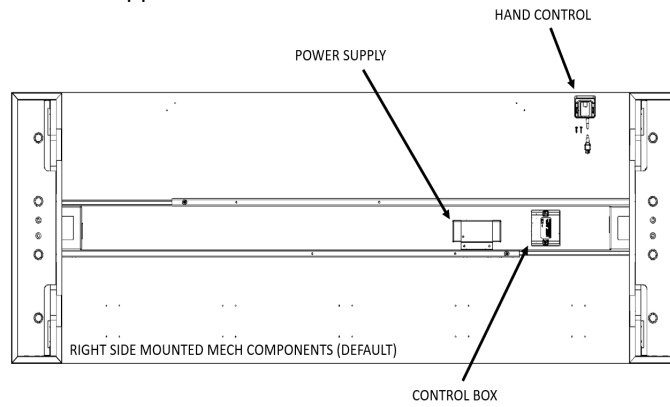

Figure L

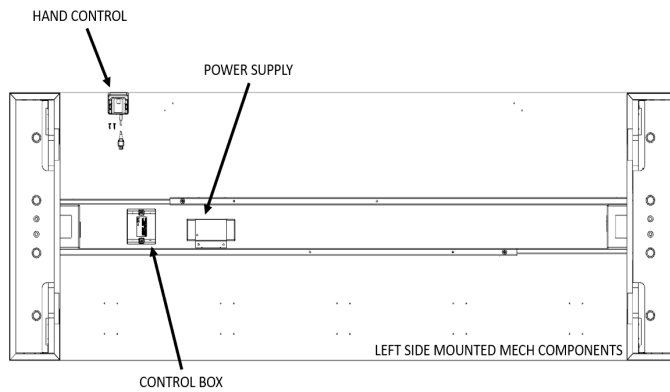

Figure M

### 6A Reconnect mechanism cables to control box.

### 7A Return to Step 7

## TESSERA HGT. ADJ. DESK

NATIONAL

Furniture with Personality®

Telephone 800.482.1717  
Fax 812.482.8800  
[www.NationalOfficeFurniture.com](http://www.NationalOfficeFurniture.com)

3206401  
Rev. -

Proper product installation, in accordance with these instructions, is the responsibility of the installing agent. If you have any questions concerning these instructions, please call National Customer Service 800.482.1717.