

1
M6 X 12
4 PCS

2
M6 X 16
1 PC

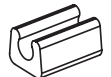

3
1 PC

4
4 PCS

STEP 01

TURN THE TABLE SURFACE UPSIDE DOWN, ALIGN B AND C TABLE LEGS ON THE BACK OF THE SURFACE AS PER THE POSITION OF THE HOLES.

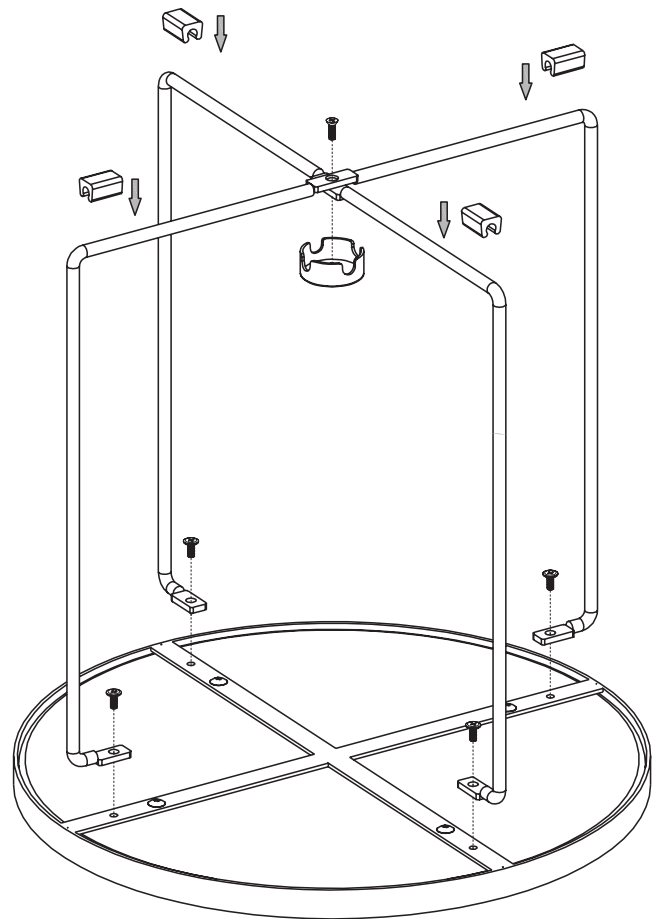

STEP 02

INSERT SCREW 1 INTO THE SURFACE THROUGH THE ROUND HOLE AND TIGHTEN THE SCREW. REPEAT THE ACTION UNTIL ALL FOUR SCREWS ARE TIGHTENED.

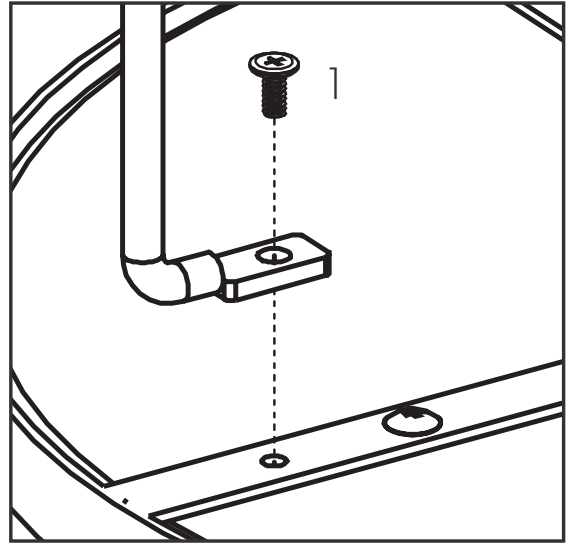

STEP 03

INSERT SCREW 2 THROUGH THE HOLE IN THE MIDDLE OF THE JUNCTION, TIGHTEN THE SCREW AND ENSURE THE IRON LID COULD BE FIXED.

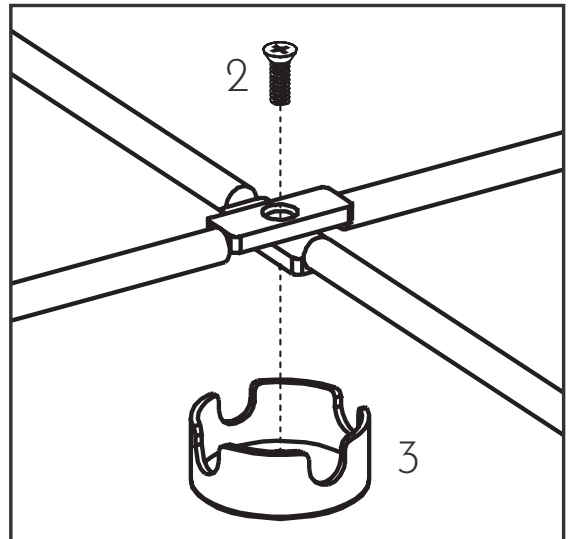

STEP 04

ATTACH THE PLASTIC COVERS AT BOTH ENDS OF THE LEGS.

