

STEP 01

PLACE SEAT ASSEMBLY UPSIDE DOWN ON AN ELEVATED FLAT SURFACE. POSITION SWIVEL TILT CONTROL MECHANISM ON BOTTOM SIDE OF SEAT ASSEMBLY TO MATCH THE INSIDE 4-HOLE CONFIGURATION.

NOTE: THE SWIVEL TILT CONTROL ADJUSTMENT KNOB IS TO BE POSITIONED TOWARD THE FRONT OF THE SEAT. THE FRONT OF THE SEAT IS IDENTIFIED BY THE FRONT ASSET LABEL. USING THE 5MM HEX KEY WRENCH, SECURE THE SWIVEL TILT CONTROL MECHANISM TO THE SEAT ASSEMBLY USING FOUR 5/16-18 X 1" HEX HEAD BOLTS.

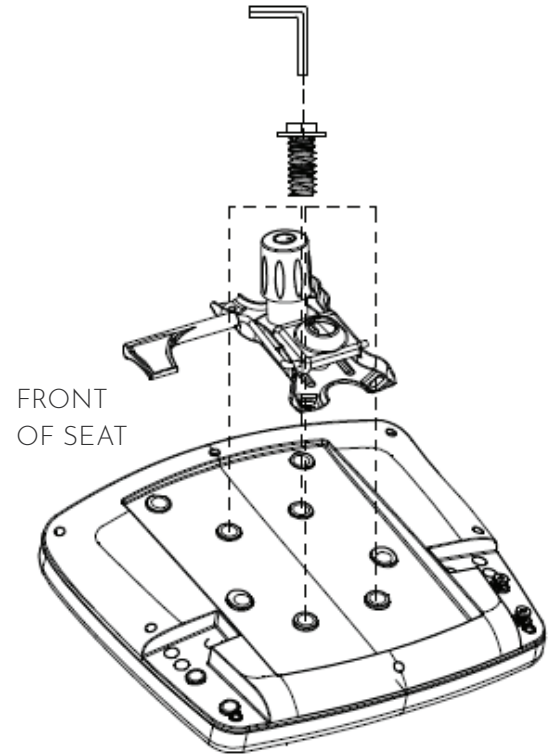

STEP 02

POSITION THE RIGHT AND LEFT ARM ASSEMBLIES ON THE BOTTOM OF THE SEAT AS SHOWN.

NOTE: TO ASSURE PROPER ASSEMBLY OF THE RIGHT AND LEFT ARMS, EACH ARM SHOULD ANGLE TOWARD THE FRONT OF THE SEAT, NOT REARWARD. USING THE 5MM HEX KEY WRENCH, SECURE EACH ARM WITH THREE 5/16-18 X 1 1/4" TRUSS HEAD BOLTS.

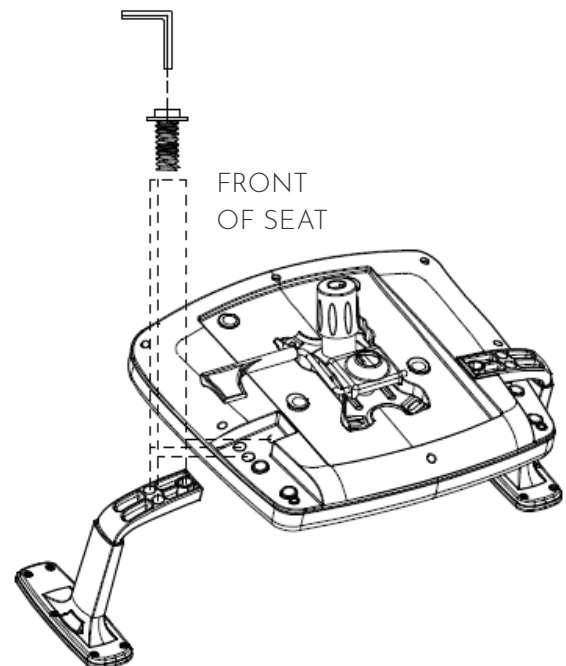

STEP 03

POSITION THE BACK ASSEMBLY TO THE CORRESPONDING HOLE CONFIGURATION ON THE BACK BOTTOM OF THE SEAT ASSEMBLY. USING THE 5MM HEX KEY WRENCH, SECURE THE BACK ASSEMBLY WITH FOUR 5/16-18 X 1 1/4" HEX HEAD BOLTS.

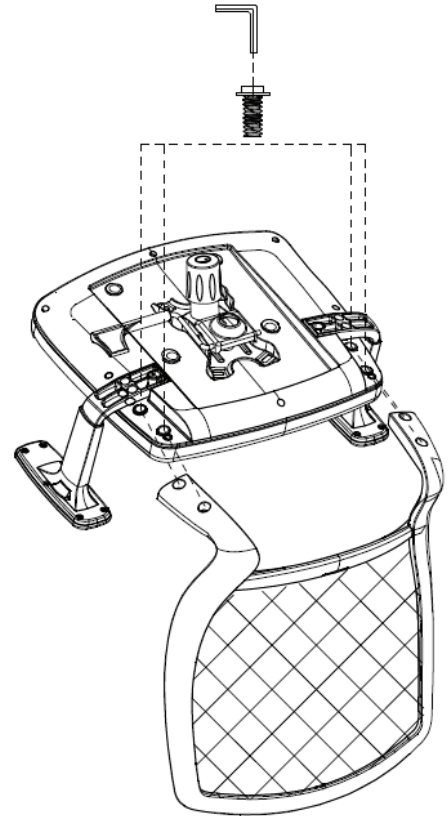
**STEP 04**

INSERT 5 CASTERS INTO THE PLASTIC BASE.

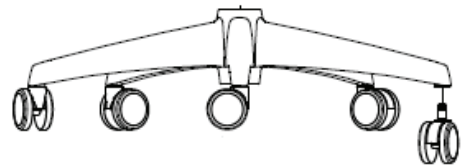

STEP 05

ORIENT THE GAS LIFT CYLINDER AS SHOWN AND INSERT THE LARGER END OF THE CYLINDER INTO THE HOLE IN THE CENTER OF THE BASE.

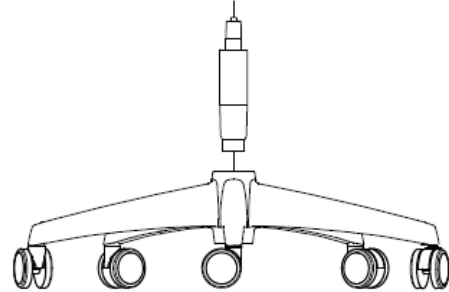
**STEP 06**

CAREFULLY POSITION THE SEAT ASSEMBLY OVER THE GAS LIFT CYLINDER, ALIGNING THE HOLE IN THE SEAT CONTROL WITH THE TOP, SMALLER END OF THE CYLINDER. PRESS THE SEAT ASSEMBLY ONTO THE CYLINDER THEN SIT ON THE SEAT TO COMPLETELY MATE THE COMPONENTS TOGETHER. WHILE SEATED, ACTUATE HEIGHT CONTROL LEVER AND REMOVE WEIGHT FROM CHAIR TO ADJUST CHAIR UP TO COMFORTABLE SITTING HEIGHT.

